



C: 32x74mm

XR400 SERIES: NT and LT APPLICATIONS with DUAL TEMPERATURE MANAGEMENT

- Advanced multifunction refrigeration controllers with dual temperature management
- Ideal for heating-cooling applications such as bain-marie with under-counter refrigerated storage
- Designed for a dual refrigeration circuit or 2 independent circuits
- Integrated defrost management
- Cooling or heating action settable by user
- Instant visibility of machine status via display icons
- Hot Key or Prog Tool Kit connector for quick and easy programming
- Serial connection to monitoring systems
- 4VA max power absorption
- Dual display with red LED (8,0mm high) and yellow LED (5,6mm high) and 14 icons

TYPICAL APPLICATIONS

1 circuit – 2 evaporators

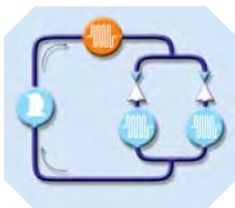

2 independent circuits



Heating and cooling application

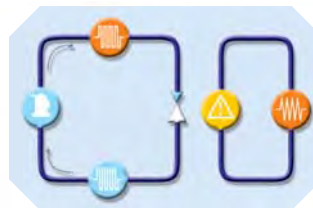

2 heating applications

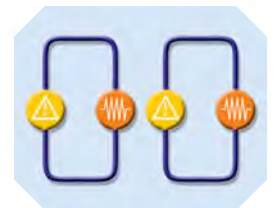

HOW to ORDER

XR400 X R 4 0 C - A B C D O

A	B	C	D
Power supply	Buzzer	RTC	Measurement unit
0 = 12Vac/dc 1 = 24Vac/dc 2 = 24Vac 4 = 110Vac 5 = 230Vac	0 = No 1 = Yes	0 = No 1 = Yes	C = °C F = °F

CONTROLLERS for STATIC or VENTILATED APPLICATIONS with DUAL TEMPERATURE MANAGEMENT

XR400

XR420C | Digital controller for NT static applications with "off cycle" defrost

XR460C | Digital controller for NT and LT for ventilated applications



C: 32x74mm

FEATURES	XR420C	XR460C
First display: n° digits	± 3 d.p.	± 3 d.p.
Second display: n° digits	± 4 d.p.	± 4 d.p.
Power supply	24, 110, 230Vac	12, 24Vac/dc
Probe inputs		
Thermostat	NTC/PTC	NTC/PTC
Thermostat 2	NTC/PTC	NTC/PTC
Defrost		NTC/PTC
Digital inputs		
Safety, start defrost, door switch	config	2 x config
Relay outputs		
Compressor	8A	8A
Compressor 2	8A	8A
Defrost		8A
Fans		8A
Light	8A	
Other		
Hot Key/Prog Tool Kit output	pres	pres
Serial output	TTL	TTL
Buzzer	opt	opt
Real time clock	opt	opt

XR420C

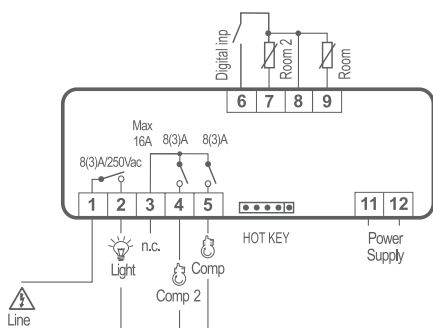

XR460C

