



COMPRESSOR RACK REFRIGERATION CONTROLLERS

SECTION INDEX

FUNCTIONS	MODELS	
XEV02 – Digital™ compressor applications		76
Driver slave for Digital™ compressor management	XEV02D	77
XC10/30 – condensing unit applications		78
Condensing unit controller	XC10CX	79
Condensing unit controller with fans management	XC30CX	79
Accessory	CAB/HK	79
XC400/600 – up to 6 compressor/fan output applications also with inverter management		80
Controller for managing up to 4 compressors/fans	XC640D	82
Controllers for managing up to 5 compressors/fans	XC450CX – XC650CX – XC652CX	82
Controllers with Digital™ compressor management	XC645CX – XC645D	82
Controller for managing up to 6 compressors/fans	XC660D	83
Keyboard for controllers in D format	VC660	83
XC1000 – up to 15 compressor/fan output applications		84
Controller for simultaneous management of up to 8 compressors and fans	XC1008D	88
Controller for simultaneous management of up to 11 compressors and fans	XC1011D	88
Controller for simultaneous management of up to 15 compressors and fans	XC1015D	89
Graphic display for XC1000 controllers	VGC810	89
iProRACK – up to 2 circuit and 6 compressor per circuit applications		90
Controllers for management of up to 2 circuits and 6 compressors per circuit	IPR208D – IPR215D	92
Graphic display for iProRACK controllers	VGIPG	92



D: 4 DIN Rail

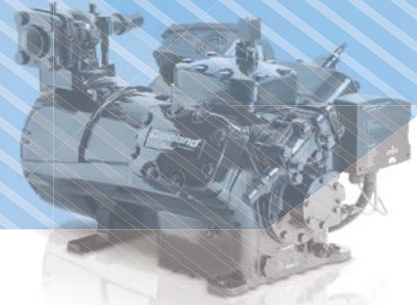

XEVO2: DIGITAL™ COMPRESSOR APPLICATIONS

- Driver slave for Digital™ compressor management
- Compatible with XC400/600, XC1000 and iProRACK controllers
- Optimal management of "Demand Cooling" applications
- Last 10 alarms recording (kind, duration)
- Temperature analog inputs (NTC86K, Pt1000)
- Pressure analog inputs (0÷5V, 4÷20mA)
- Alarm management (visual or through digital output)
- Digital inputs (1 insulated, 1 voltage)
- Hot Key or Prog Tool Kit connector for quick and easy programming
- Serial connection to monitoring systems
- 6VA max power absorption
- Display with red LED (10,5mm high) and icons

HOW to ORDER

XEVO2D X E V O 2 D - A B C D O

A	B	C	D
Power supply	Temperature probe	Pressure probe	Measurement unit
2 = 24Vac 4 = 110Vac 5 = 230Vac	N = NTC86K P = Pt1000	0 = No 1 = 0÷5V 2 = 4÷20mA 3 = PP11 4 = PP30 5 = PPR15 6 = PPR30	B = Bar/°C P = PSI/°F H = KPA/°C

XEV02D | Driver slave for Digital™ compressor management with triac and open collector outputs



D: 4 DIN Rail

FEATURES	XEV02D
Display: n° digits	± 3 d.p.
Keyboard: push buttons	4
Power supply	24, 110, 230Vac
Probe inputs	
Suction pressure	4÷20mA, 0÷5V
Discharge line temperature (DLT)	NTC86K, Pt1000
Digital inputs	
Free of voltage	pres
High voltage	pres
Relay outputs	
Alarm	8A config
Other	
Triac output	pres
Open collector output	config
Hot Key/Prog Tool Kit output	pres
Serial output	RS485
Buzzer	pres

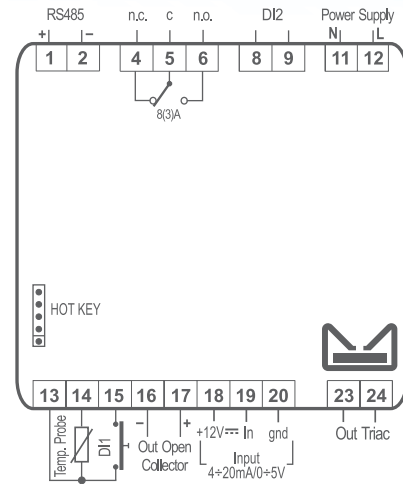

COMPATIBILITY with DIXELL CONTROLLERS

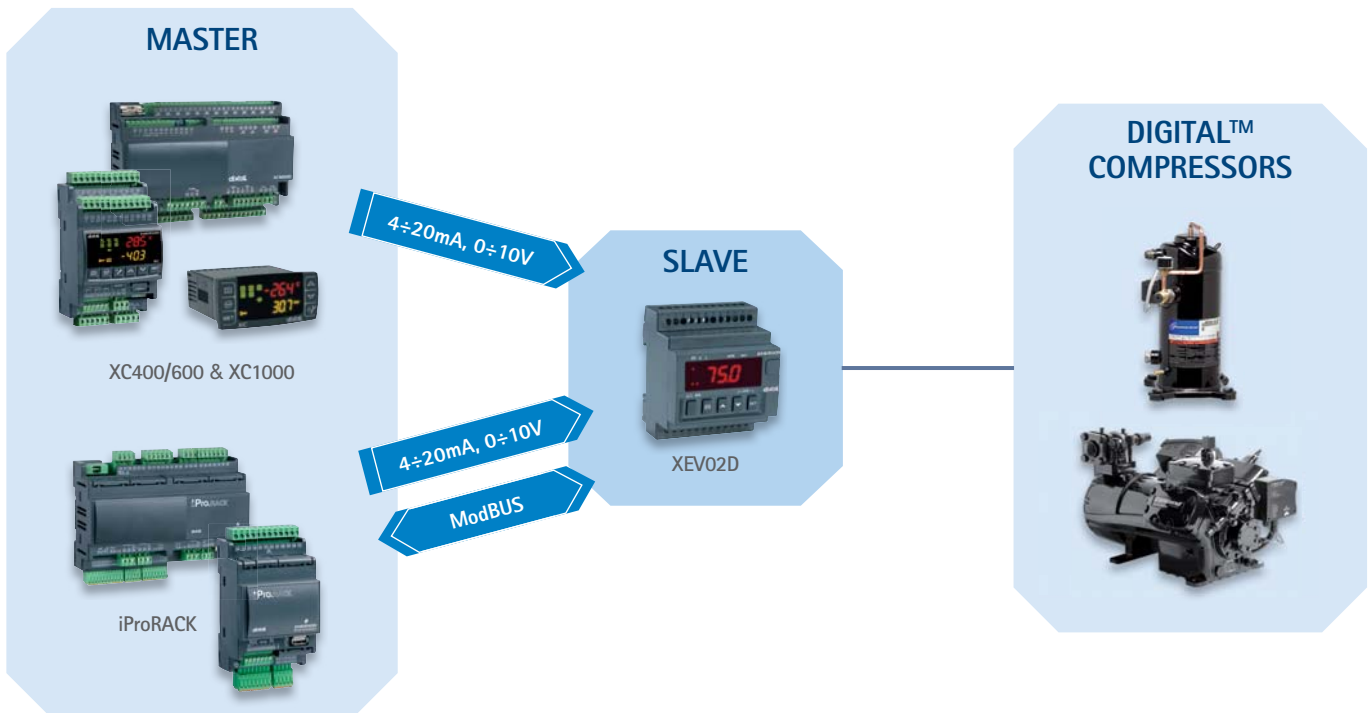



CX: 32x74mm



XC10/30 SERIES: CONDENSING UNIT APPLICATIONS

- Electronic controllers for condensing unit management with alarm log
- Smart error pressure probe management
- External trigger signal to enable regulation (**fig. 1**)
- Flooded start protection
- Suction and discharging lines temperature control
- Compressor working time and activation counters
- Safety control of high pressure and high condensing/suction temperature
- Fan cycling management to share the working load
- Direct access to alarm menu, working time and load activation
- Management of 1 compressor and up to 2 fans (XC30CX)
- Hot Key or Prog Tool Kit connector for quick and easy programming
- 3VA max power absorption
- Display with red LED (10,5mm high) and icons

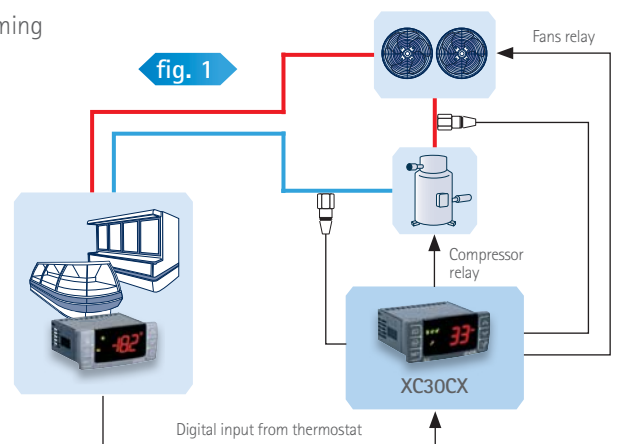

HOW to ORDER

XC10/30 X C O C X - A B C O E

A	B	C	E
Power supply	Measurement unit	Buzzer	Input
4 = 110Vac 5 = 230Vac	B = Bar/°C P = PSI/°F H = KPA/°C	0 = No 1 = Yes	G = 0÷5V (suction)/NTC (condensing) H = 0÷5V (suction)/0÷5V (condensing)

- XC10CX** | Condensing unit controller with 1 compressor
- XC30CX** | Condensing unit controller with 1 compressor and 2 fans



CX: 32x74mm

FEATURES	XC10CX	XC30CX
Display: n° digits	± 3 d.p.	± 3 d.p.
Power supply	110, 230Vac	110, 230Vac
Probe inputs		
Suction pressure	0÷5V	0÷5V
Condensing pressure	0÷5V, NTC	0÷5V, NTC
Discharge temperature	PTC	PTC
Digital inputs		
High pressure safety	pres	pres
Thermostat	pres	pres
Relay outputs		
Compressor	20A	20A
Fans		8A
Fans 2		5A
Other		
Hot Key/Prog Tool Kit output	pres	pres
Buzzer	opt	opt

XC10CX

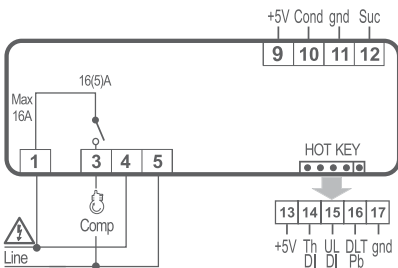

XC30CX

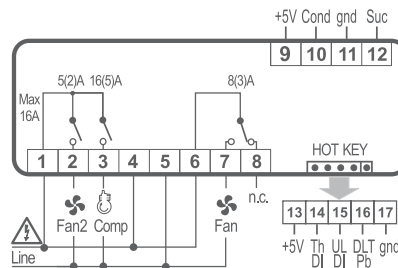

FAN MANAGEMENT

XC30CX has 2 outputs to drive 2 different condensing fans. A smart fan algorithm shares the fan working time between the outputs

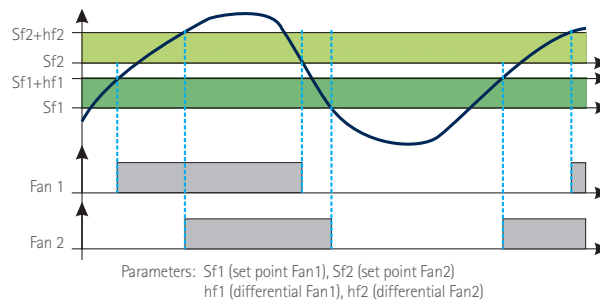

ACCESSORY

CAB/HK

Adapter cable, 5 pins for Hot Key input, 0,5m





D: 4 DIN Rail



CX: 32x74mm



100x64mm

XC400/600 SERIES: up to 6 COMPRESSOR/FAN OUTPUT APPLICATIONS also with INVERTER MANAGEMENT

- Electronic controllers for compact compressor racks management also with inverter
- Compressor types: Digital™, multi-stages, differing power, semi-hermetic, scroll and screw
- Proportional band or neutral zone control
- Floating condensing pressure control depending on the external temperature
- High configurability and flexibility
- Automatic switch-off of the compressors in case of high condensing pressure/temperature
- Silent mode function for fans during the night
- Correct lubrication automatic restore cycle
- Safer control with low pressure electronic pressure switch
- Type of gas setting: to control temperature or pressure
- Hot Key or Prog Tool Kit connector for quick and easy programming
- Serial connection to monitoring systems
- 5VA max power absorption
- Dual display with red LED (8,5mm high) and yellow LED (7,5mm high) and 17 icons

HOW to ORDER

XC400/600CX X C C X - A B C D E

XC600D X 6 D - A B 1 D E

VC660 V C 6 6 0 - 0 0 C 0 0

A	B	C	D	E
Power supply*	Measurement unit	Buzzer	TRIAC voltage**	Analog outputs
0 = 12Vac/dc	C = °C	0 = No	0 = 110÷230Vac	No
1 = 24Vac/dc	F = °F	1 = Yes	1 = 110÷230Vac	Yes
4 = 110Vac	B = Bar		2 = 24Vac	No
5 = 230Vac	P = PSI		3 = 24Vac	Yes
	H = KPA		4 = No TRIAC	No
			5 = No TRIAC	Yes
				Input
				A = PP11 (only for XC450CX)
				B = PP30 (only for XC450CX)
				C = NTC
				E = 4÷20mA
				F = PP11 (suction)/PP30 (discharge)
				H = 0÷5V (ratiometric)

* 0, 1 (only for XC400CX and XC600CX)
4, 5 (only for XC600D)

** 0, 1, 2, 3 (only for XC645)
4, 5 (not for XC645)

TYPE of COMPRESSOR RACKS

The XC400/600 series, thanks to a powerful and complete range, ensures optimal management of compact compressor racks:

- with compressors and fans also with suction or discharge inverter;
- with 2 discharge and 1 suction also with inverter;
- with Digital™ compressors.

XC645CX - XC645D
APPROVED FOR



Example of circuits managed by the XC400/600 series

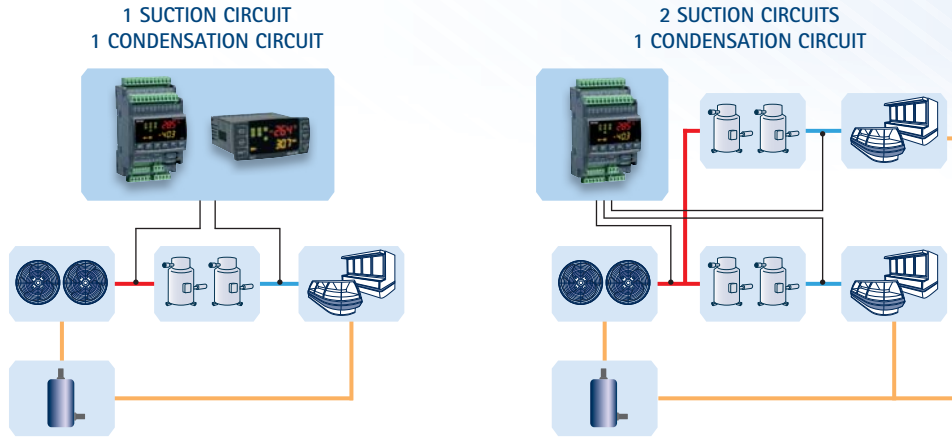

CONNECTIONS

2 different version of terminal block are available depending on the model of the controllers:

Screws for XC400CX



Disconnectable for XC600CX



Screw disconnectable for XC600D



FLOATING CONDENSING

The dynamic set point guarantees excellent plant efficiency, taking real operational conditions into consideration. The condensing set point is automatically adjusted according to the external temperature, keeping the safety values, to optimize the condensing temperature. The reduction of this temperature entails a reduction of the pressure gap between suction and condensing decreasing the consumption of compressors and saving energy.

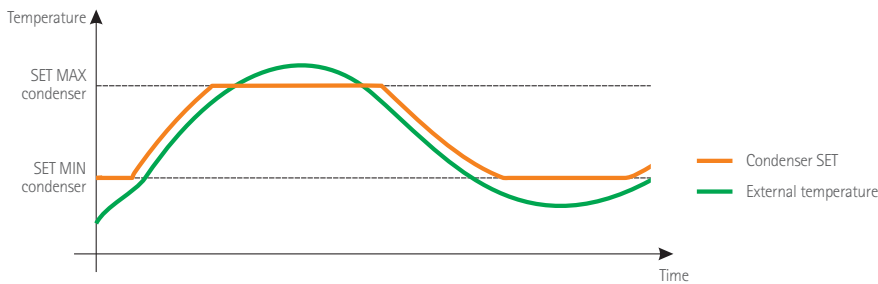

FAN FUNCTIONING DURING NIGHT MODE

This special function allows the maximum fan speed to be decreased, which reduces plant noise. Thanks to the MES (Maximum output during Energy Saving) the maximum fan speed is reduced during the night.

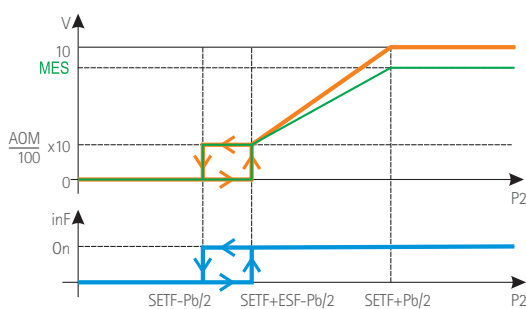

- SETF: supply pressure setting to be maintained
- Pb/2: regulation band centred around the setting
- AOM: minimum allowed speed for the fans
- inF: relay set as fan inverter
- P2: condensing pressure (temperature) probe
- V: analogical output value set as 0÷10V
- ESF: energy saving differential for fan regulation

XC400/600

Up to 5 COMPRESSOR/FAN COMPRESSOR RACK CONTROLLERS also with INVERTER MANAGEMENT



CX: 32x74mm

D: 4 DIN Rail

XC450CX	Digital controller for managing up to 5 compressors or fans
XC640D	Digital controller for simultaneous management of up to 4 compressors and fans
XC645CX XC645D	Digital controllers for Digital™ compressor management

FEATURES	XC450CX	XC640D	XC645CX	XC645D
First display: n° digits	± 4 d.p.	± 4 d.p.	± 4 d.p.	± 4 d.p.
Second display: n° digits	± 4 d.p.	± 4 d.p.	± 4 d.p.	± 4 d.p.
Power supply	12, 24Vac/dc	110, 230Vac	12, 24Vac/dc	110, 230Vac
Probe inputs				
Suction	0÷5V, 4÷20mA, NTC	0÷5V, 4÷20mA, NTC	0÷5V, 4÷20mA, NTC	0÷5V, 4÷20mA, NTC
Suction 2				
Condensing	0÷5V, 4÷20mA, NTC	0÷5V, 4÷20mA, NTC	0÷5V, 4÷20mA, NTC	0÷5V, 4÷20mA, NTC
Configurable		NTC	NTC	NTC
Digital inputs				
Low pressure switch		1	1	1
High pressure switch		1	1	1
Alarm	5	4	4	5
Configurables	1	2	1	2
Relay outputs				
Loads	5 x 5A	4 x 5A	4 x 5A	4 x 5A
Other outputs				
Digital™ compressor			TRIAC	TRIAC
Inverter-compressor		4÷20mA/0÷10V opt		4÷20mA/0÷10V opt
Inverter-fans		4÷20mA/0÷10V opt		4÷20mA/0÷10V opt
Load			4÷20mA/0÷10V opt	
Hot Key/Prog Tool Kit	pres	pres	12V/40mA	pres
Serial	TTL	RS485	TTL	RS485
Other				
Remote keyboard		VC660		VC660
Alarms	last 10	last 10	last 10	last 10
Buzzer	opt	pres	opt	pres
Connection kit			CWC15-KIT, CWC30-KIT, CAB/CJ15, CAB/CJ30	

XC450CX

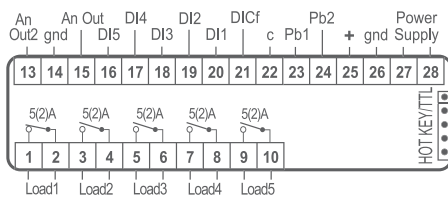

XC645CX

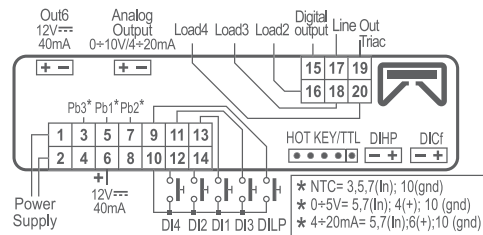

XC640D

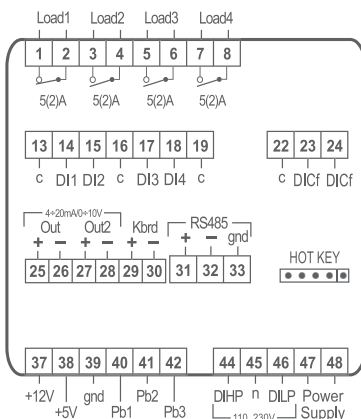

XC645D

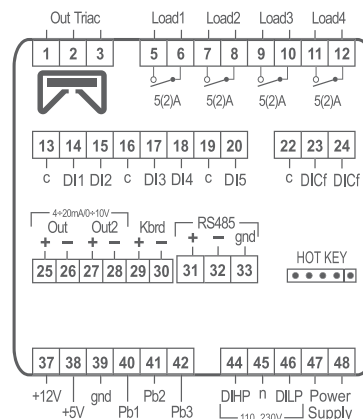

Up to 6 COMPRESSOR/FAN COMPRESSOR RACK CONTROLLERS and KEYBOARD also with INVERTER MANAGEMENT

XC600

XC650CX	Digital controller for simultaneous management of up to 5 compressors and fans
XC652CX	Compressor rack digital controller with 2 suction
XC660D	Digital controller for simultaneous management of up to 6 compressors and fans
VC660	Keyboard for XC600D controllers



CX: 32x74mm D: 4 DIN Rail 100x64mm

FEATURES	XC650CX	XC652CX	XC660D	VC660
First display: n° digits	± 4 d.p.	± 4 d.p.	± 4 d.p.	± 4 d.p.
Second display: n° digits	± 4 d.p.	± 4 d.p.	± 4 d.p.	± 4 d.p.
Power supply	12, 24Vac/dc	12, 24Vac/dc	110, 230Vac	from controller
Probe inputs				
Suction	0÷5V, 4÷20mA, NTC	0÷5V, 4÷20mA, NTC	0÷5V, 4÷20mA, NTC	
Suction 2		0÷5V, 4÷20mA, NTC		
Condensing	0÷5V, 4÷20mA, NTC	NTC	0÷5V, 4÷20mA, NTC	
Configurable	NTC		0÷5V, 4÷20mA, NTC	
Digital inputs				
Low pressure switch	1	1	1	
High pressure switch	1	1	1	
Alarm	4	4	6	
Configurables	1	1	2	
Relay outputs				
Loads	5 x 5A	5 x 5A	6 x 5A	
Other outputs				
Digital™ compressor				
Inverter-compressor	4÷20mA/0÷10V opt	4÷20mA/0÷10V opt	4÷20mA/0÷10V opt	
Inverter-fans	4÷20mA/0÷10V opt	4÷20mA/0÷10V opt	4÷20mA/0÷10V opt	
Load	12V/40mA	12V/40mA		
Hot Key/Prog Tool Kit	pres	pres	pres	
Serial	TTL	TTL	RS485	
Other				
Remote keyboard			VC660	
Alarms	last 10	last 10	last 10	
Buzzer	opt	opt	pres	opt
Connection kit	CW15-KIT, CW25-KIT, CAB/CJ15, CAB/CJ30	CW15-KIT, CW25-KIT, CAB/CJ15, CAB/CJ30		

XC650CX - XC652CX

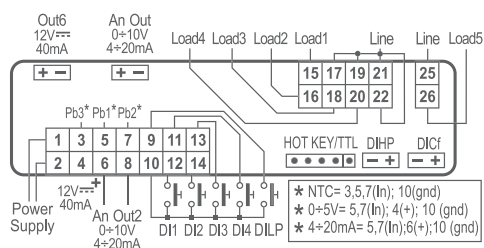

XC660D

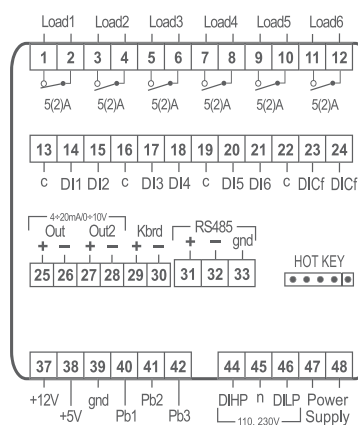



D: 10 DIN Rail



VG: 82x156mm

XC1000 SERIES: up to 15 COMPRESSOR/FAN OUTPUT APPLICATIONS

- Electronic controllers for compressors and condensing fans management of medium-large compressor racks
- Scroll, semi-hermetic, multi stages, with different power and screw compressor management
- Concise information about the variables of the compressor rack through the VISOGRAPH display
- 2 analogue outputs for frequency compressors
- 2 analogue outputs for inverter for fans
- Hourly run time signals for maintenance
- Sub-cooling management
- Subcritical CO₂ regulation
- Compressor unloading in case of high condensing pressure alarm
- Suction superheat calculation with alarm management and possible stop of compressors
- Liquid injection valve activation to increase superheat
- Alarm management with absolute and relative pressure
- Hot Key or Prog Tool Kit connector for quick and easy programming
- Serial connection to monitoring systems
- 12VA max power absorption

HOW to ORDER

XC1000D

X	C	1	0		D	-	1	B	0	D	E
---	---	---	---	--	---	---	---	---	---	---	---

B	D	E
Measurement unit	4÷20mA/0÷10V	Inputs
C = °C	0 = No	C = NTC
F = °F	1 = Yes	D = PTC
B = Bar		E = 4÷20mA
P = PSI		F = Suction PP11; Condensing PP30
K = KPA		G = Ratiometric

VGC810

V	G	C	8	1	0	-	A	B	0	0	0
---	---	---	---	---	---	---	---	---	---	---	---

A	B
Buzzer	Kind of mounting
0 = No	P = Panel
1 = Yes	W = Wall

KINDS OF CIRCUIT

The XC1000D series is able to manage in the best possible way the majority of applications for refrigeration circuits.

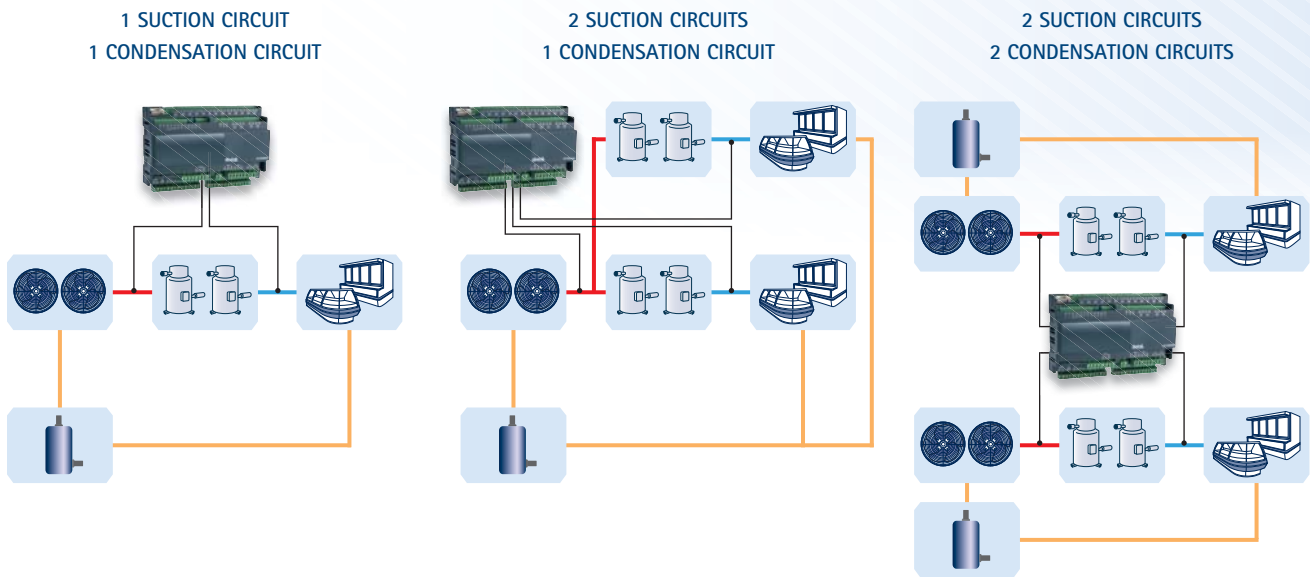

CO₂ REGULATION

CO₂ use is increasing thanks to the advantages it offers in cooling plants. For this reason there is also a greater demand for accessories. Thanks to special algorithms, the XC1000D series can manage and monitor CO₂ plants that work in cascade connection with sub-critical cycle.



COMPATIBILITY with DIGITAL™ COMPRESSORS

Thanks to its powerful hardware platform and to the advanced algorithms, the XC1000D family is able to drive the majority of compressor racks present in the market. An interesting match is the one with Dixell XEV02D driver that allows management of compressor racks equipped with Digital™ compressors. In these applications, by using the modulating capacity, the plant receives the optimum refrigeration power thereby reducing consumption.

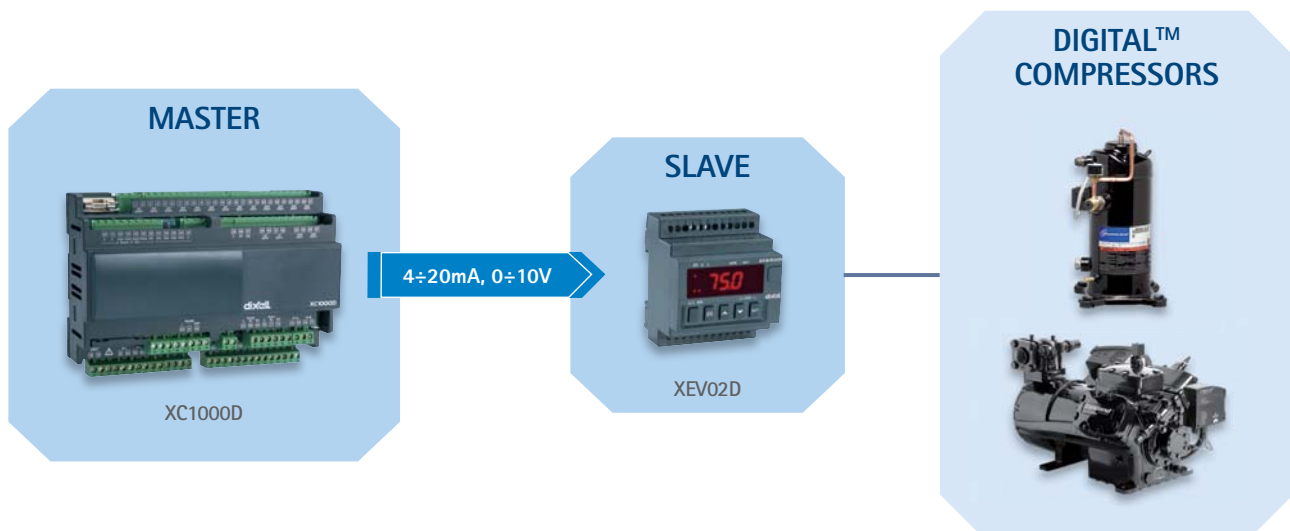

ENERGY SAVING MANAGEMENT

The XC1000D series gives to the user several solutions that let you to manage energy savings. The controllers have a special algorithm that lets you to optimize the efficiency of the plant, ensuing energy savings. The following are a range of the most important solutions that Dixell offers to customers to achieve energy savings.

COMPRESSORS with INVERTER

When the plant needs more power (when the temperature gets out of the band) the inverter compressor frequency increases. If this is not enough, the other compressors (C2, C3, ...) will be activated in sequence. At the same time the controller will modulate the inverter compressor frequency in order to have a uniform increase of the plant power.

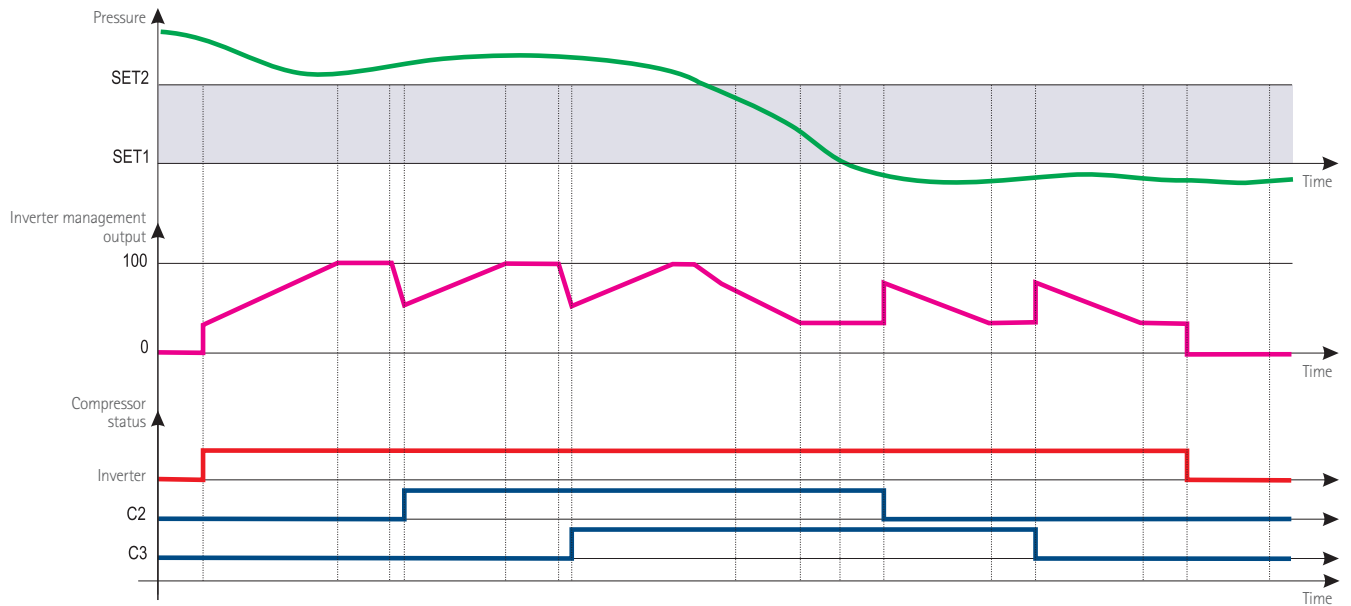

EC FANS – INVERTER

In this case all condensing fans are driven by one inverter or are EC fans.

The inverter power is proportional to the condensing pressure value and the analog output is modulated proportionally to the condensing pressure/temperature over the set ($SET1 \div SET2$). Under SET1 the output will be switched off, over the SET2 the output is at 100%.

The relay set as inverter will be activated if the condensing pressure/temperature is higher than the SET1 and switched off when the condensing pressure is lower than the SET1. It can be used to allow the inverter regulation.

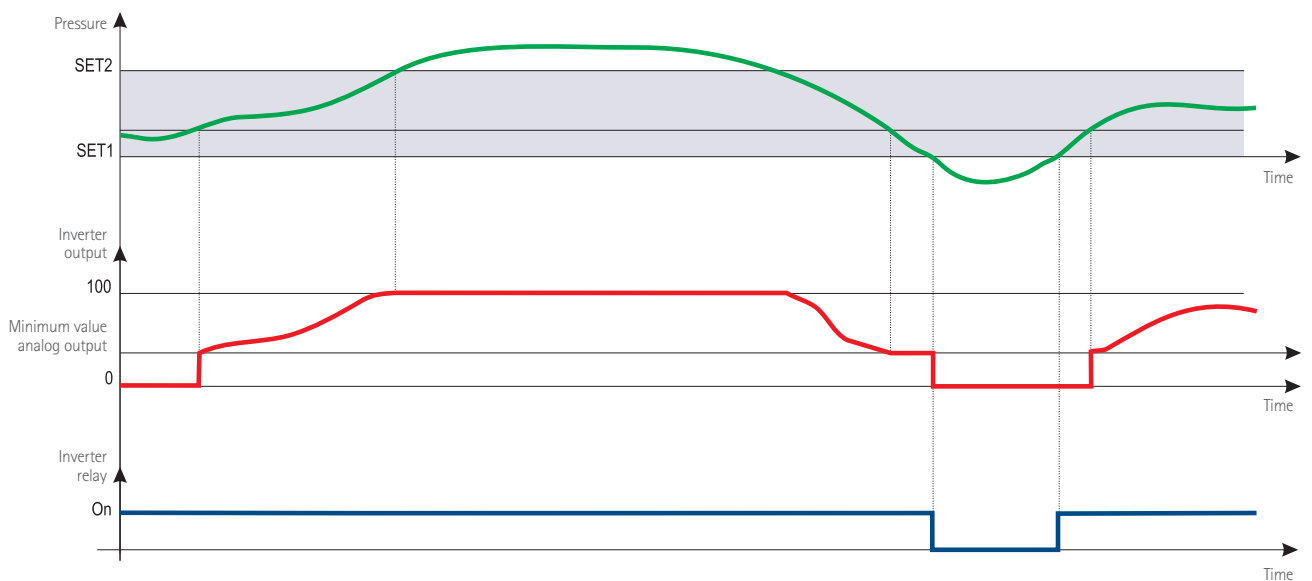

SUCTION DYNAMIC SET POINT

Suction temperature/pressure optimization can depend on retail space temperature.

The dynamic set point guarantees excellent plant efficiency, considering the real operational conditions. The plant modifies the suction temperature/pressure according to the retail space temperature so the refrigeration power changes depending on the real thermodynamic exchange.

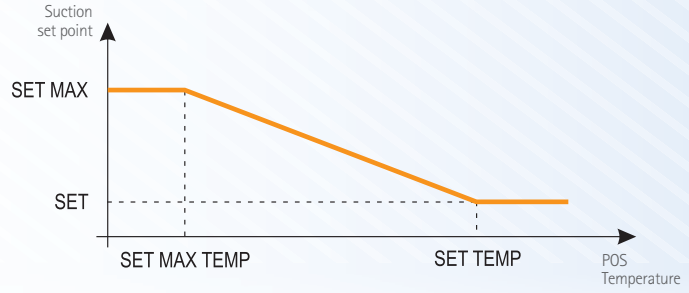

CONDENSER DYNAMIC SET POINT

Condenser temperature/pressure optimization can depend on the external temperature.

The condenser temperature/pressure is modified according to the external temperature. The condensing set point is automatically adjusted according to the external temperature, to get an optimum condensing temperature.

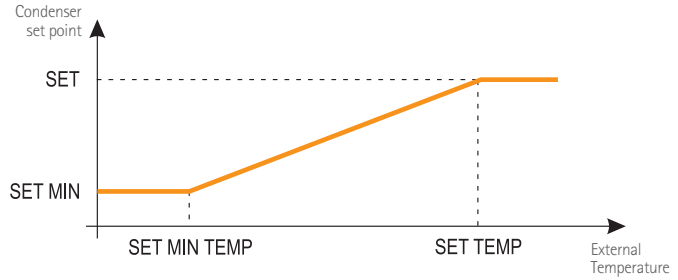

REDUCED SET POINT

An internal 7 day clock can automatically change the adjustment's set point, depending on a particular system's individual requirements, to enter an energy saving cycle during nights and weekends, when less power is required. This energy saving cycle can also be initiated from an external source via a digital input.

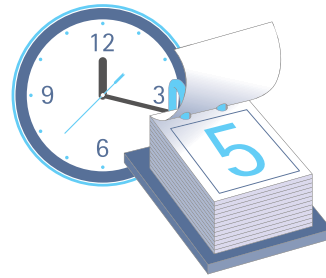

SUPERVISION SET

The connection to the modern supervising systems (of Dixell) allows, thanks to the **CRO (Compressor Rack Optimization)**, to manage in the best way the compressor rack set point depending on the devices connected, with the result of having an optimized energy saving on the plant. The system, equipped with the CRO function, analyzes the information from the controller in the application to determine if a controller needs more refrigeration power and the quantity. The set point will be re-calculated in order to satisfy the worse instance and sent from the supervising system to the XC1000D; this will be the working set point (**fig. 1**). If the supervising system can't manage the XC1000D, is the controller that "decided" to replace the set point (coming from the system) and will then define the set point in the program phase.

The 2 graphs (**fig. 2**) emphasize that when the CRO algorithm is active, in a real installation, the set point becomes on average higher, and consequently the energy consumption decreases. The dotted line represents the average weekly value.

fig. 1

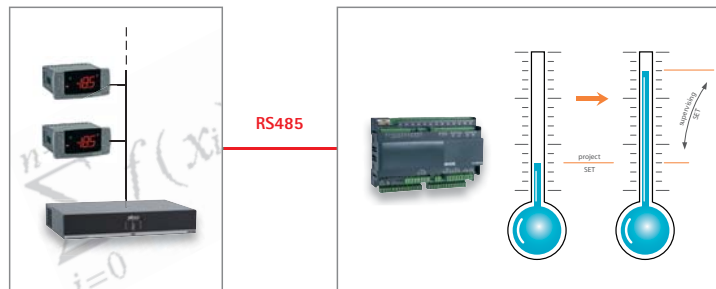
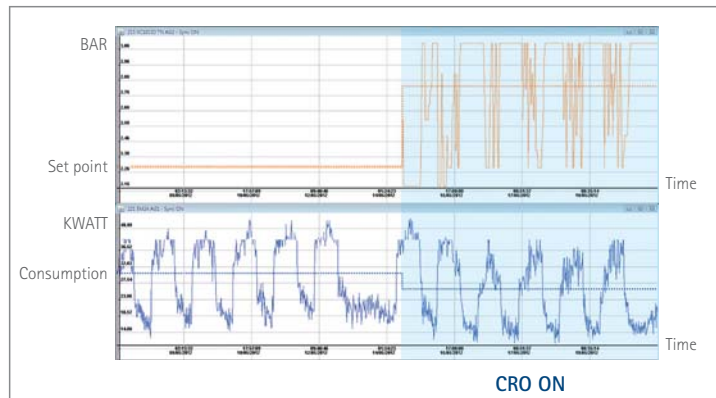
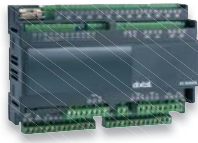

fig. 2



XC1000

Up to 11 COMPRESSOR and FAN COMPRESSOR RACK CONTROLLERS



D: 10 DIN Rail

- XC1008D** | Digital controller for simultaneous management of up to 8 compressors and fans
- XC1011D** | Digital controller for simultaneous management of up to 11 compressors and fans

FEATURES	XC1008D	XC1011D
Display	LCD on VGC810	LCD on VGC810
Power supply	24Vac/dc (from TF10D)	24Vac/dc (from TF20D)
Probe inputs		
Suction	NTC, PTC, 4÷20mA, 0÷5V	NTC, PTC, 4÷20mA, 0÷5V
Suction 2		NTC, PTC, 4÷20mA, 0÷5V
Condensing	NTC, PTC, 4÷20mA, 0÷5V	NTC, PTC, 4÷20mA, 0÷5V
Condensing 2		NTC, PTC, 4÷20mA, 0÷5V
Auxiliary	NTC, PTC	NTC, PTC
Auxiliary 2	NTC, PTC	NTC, PTC
Auxiliary 3		NTC, PTC
Auxiliary 4		NTC, PTC
Digital inputs		
Low pressure switch	1	1
Low pressure switch 2		1
High pressure switch	1	1
High pressure switch 2		1
Safety loads	8	11
Configurable	4	4
Relay outputs		
Loads	8 x 7A config	11 x 7A config
Alarms	2 x 8A	2 x 8A
Other outputs		
Inverter compressors	4÷20mA/0÷10V opt	2 x 4÷20mA/0÷10V opt
Inverter fans	4÷20mA/0÷10V opt	2 x 4÷20mA/0÷10V opt
Hot Key/Prog Tool Kit	pres	pres
Visokey		
Serial	RS485	RS485
Other		
Remote display	VGC810	VGC810
Alarms	last 100	last 100
Buzzer	on keyboard	on keyboard

XC1008D – XC1011D

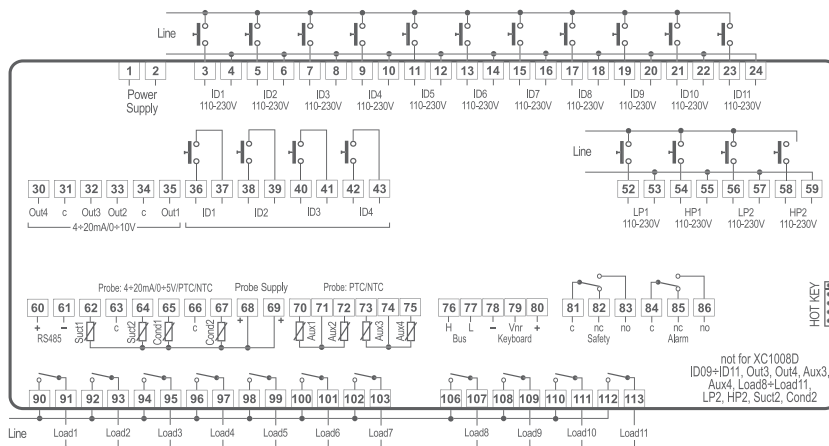

CONTROLLER and GRAPHIC DISPLAY for COMPRESSOR RACKS with up to 15 COMPRESSORS and FANS

XC1000

- XC1015D** | Digital controller for simultaneous management of up to 15 compressors and fans
- VGC810** | Remote keyboard with LCD graphic display and interface dedicated to the management of compressor racks by means of XC1000D controllers (IP65 front protection)

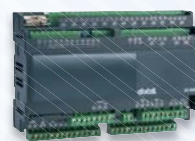

D: 10 DIN Rail



VG: 82x156mm

FEATURES	XC1015D	VGC810
Display	LCD on VGC810	LCD - 240x96pixels
Power supply	24Vac/dc (from TF20D)	from controller
Probe inputs		
Suction	NTC, PTC, 4÷20mA, 0÷5V	
Suction 2	NTC, PTC, 4÷20mA, 0÷5V	
Condensing	NTC, PTC, 4÷20mA, 0÷5V	
Condensing 2	NTC, PTC, 4÷20mA, 0÷5V	
Auxiliary	NTC, PTC	
Auxiliary 2	NTC, PTC	
Auxiliary 3	NTC, PTC	
Auxiliary 4	NTC, PTC	
Digital inputs		
Low pressure switch	1	
Low pressure switch 2	1	
High pressure switch	1	
High pressure switch 2	1	
Safety loads	15	
Configurable	4	
Relay outputs		
Loads	15 x 7A config	
Alarms	2 x 8A	
Other outputs		
Inverter compressors	2 x 4÷20mA/0÷10V opt	
Inverter fans	2 x 4÷20mA/0÷10V opt	
Hot Key/Prog Tool Kit	pres	
Visokey		pres
Serial	RS485	
Other		
Remote display	VGC810	
Alarms	last 100	
Buzzer	on keyboard	opt

XC1015D

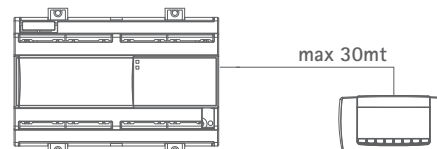
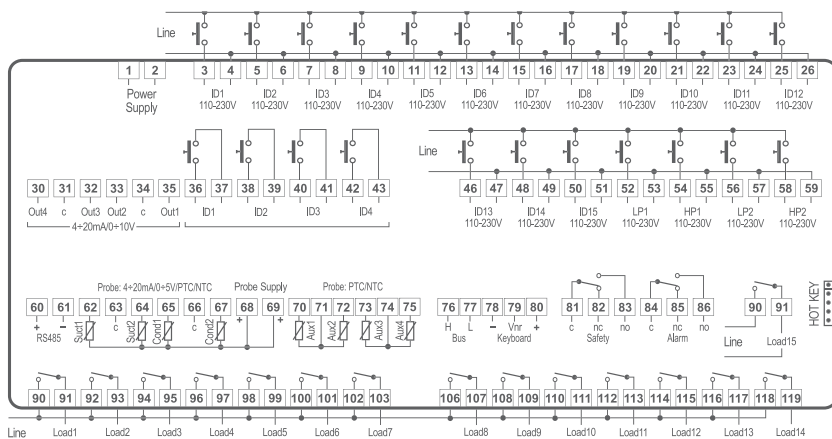



iProRACK SERIES: up to 2 CIRCUIT and 6 COMPRESSOR per CIRCUIT APPLICATIONS

- Electronic controllers for compressor racks studied to manage even the most complex installations
- Management of scroll, semi-hermetic, multi-stages, different capacity and screw compressors
- Management of 2 circuits with 2 inverters
- Transcritical CO₂ regulation
- Special algorithms for energy saving
- Suction and condensing dynamic set point optimization
- Sub-cooling management
- Copeland Stream CoreSense™ diagnostics control module integration
- Concise information about the variables of the compressor rack through the VISOGRAPH
- Powerful platform with LINUX operating system on CPU ARM9 (200MHz/32bit)
- Ethernet for the connection to an intranet-internet network
- USB output for configuration update
- RS485 slave serial outputs for the connection to XWEB supervising and controlling systems
- Type of refrigerants: R22, R134A, R404A, R507, R717, R407, R407C, R407F

HOW to ORDER

IPR208D I P R 2 0 8 D - 1 0 C 2 0

IPR215D I P R 2 1 5 D - 1 0 C 0 0

C

Ethernet, protocols

0 = No

1 = Yes

VGIPG V G I P G - A B O D O

A

B

D

Buzzer	Kind of mounting	Coding
0 = No	P = Panel	0 = Ascii
1 = Yes	W = Wall	1 = Unicode

INTERNAL WEB SERVER

The iProRACK controllers have an integrated web site that can be easily reached through a standard browser. This instrument is very useful to configure the controller and to display and change the machine variables.

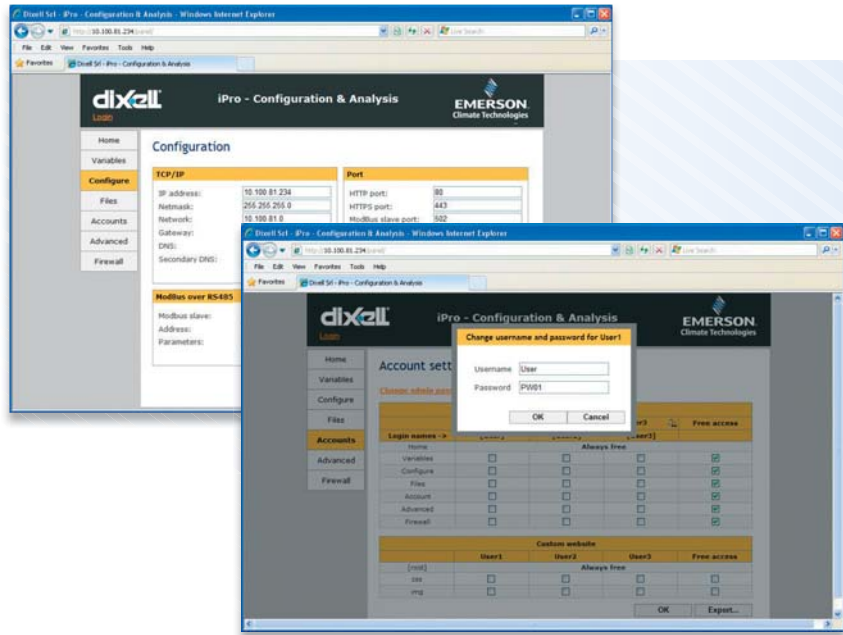

MAIN FEATURES

- CPU: 200MHz
- Processor: 32bit
- RAM memory: 32MB (4 DIN Rail), 64MB (10 DIN Rail)
- Data storage on Flash memory: 32MB (4 DIN Rail), 128MB (10 DIN Rail)
- Power absorption: 40VA max (4 DIN Rail), 20VA max (10 DIN Rail)

CONNECTIVITY

The powerful platform that marks the iProRACK controllers and allows the compressor rack to be easily and quickly reached both locally and remotely. In addition to the connection via Ethernet, there is also one via RS485 that allows the connection to XWEB systems, ensuring complete plant monitoring and controlling.

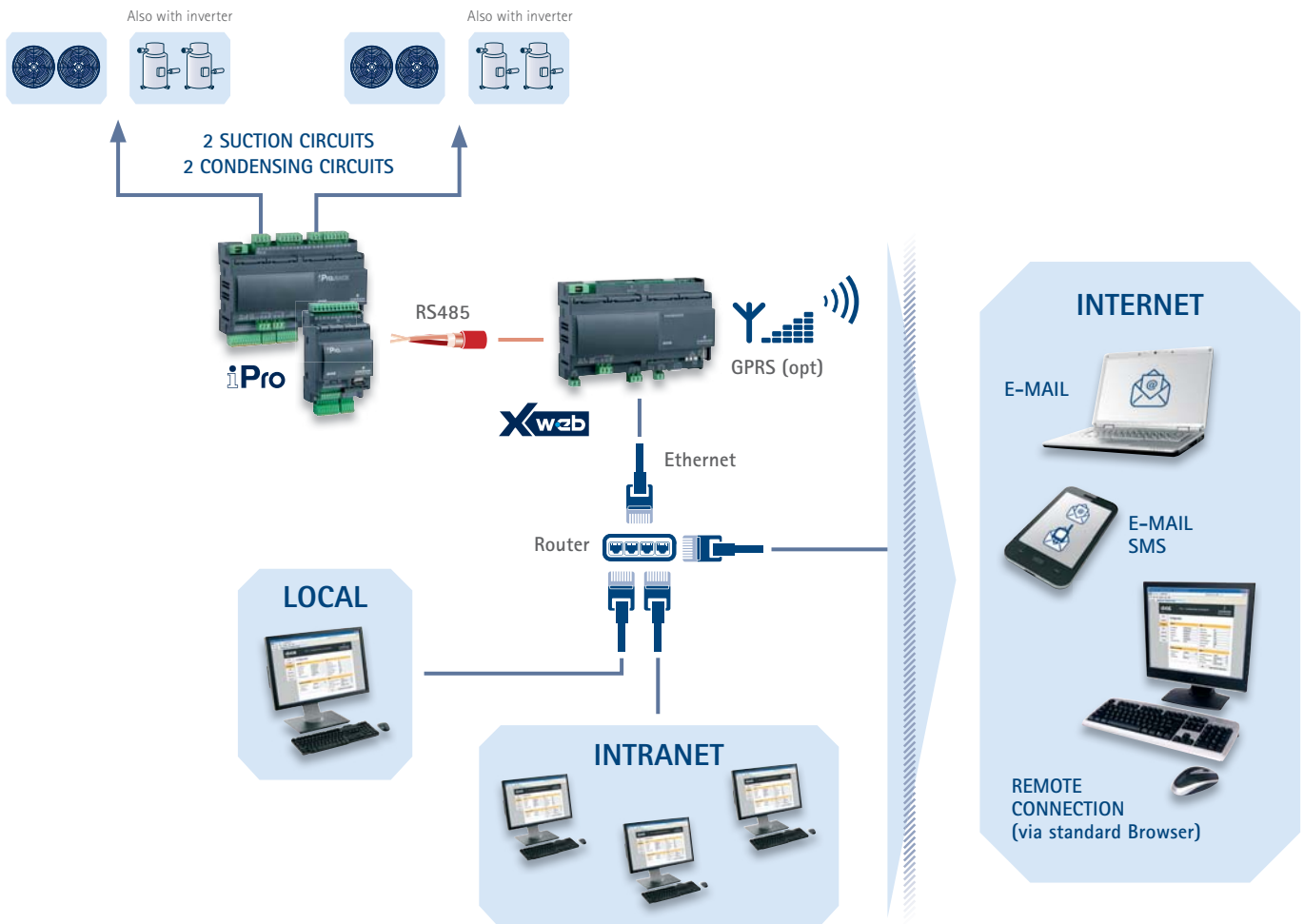

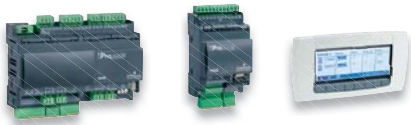

D: 10 DIN Rail D: 4 DIN Rail VG: 82x156mm

IPR208D	Digital controller in 4 DIN Rail format with bayonet + screw connectors for compressor rack management
IPR215D	Digital controller in 10 DIN Rail format with bayonet + screw connectors for compressor rack management
VGIPG	Remote keyboard with LCD graphic display and interface dedicated to the management of compressor racks by means of iProRACK controllers (IP65 front protection)

FEATURES	IPR208D	IPR215D	VGIPG
Display	LCD on VGIPG	LCD on VGIPG	LCD - 240x96pixels
Power supply	24Vac/dc from TF40D	24Vac/dc from TF20D	from controller
Probe inputs			
0÷1V, 0÷5V, 0÷10V, 0÷20mA, 4÷20mA, NTC, PTC, DI	6 x config	10 x config	
Digital inputs			
Opto-insulated	11 x config	20 x config	
Relay outputs			
Configurable	8 x 5A	15 x 5A	
Other outputs			
0÷10V/4÷20mA	4 x config	2 x config	
0÷10V		4	
RS485	master + slave	master + slave	
USB	pres	pres	
CANBus		pres	
Ethernet	via USB-ETH-CONV	opt	
Visokey			pres
Other			
Remote display	1 x VGIPG	2 x VGIPG	
Real time clock	pres	pres	
Flash memory	32MB	128MB	
Connections	bayonet + screw	bayonet + screw	
Connection kit	IP-FC208	IP-FC215CP	
BACnet protocol	opt	opt	
Buzzer			opt

IPR208D

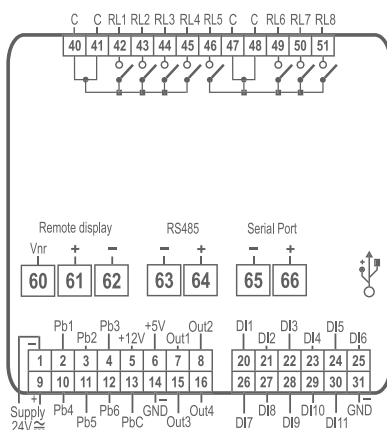

IPR215D

