

XJM ***I/O module***



XJM60D



XJM60D

Multifunction I/O module for data acquisition

Application Fields

Acquisition and actuator module for:

- **REFRIGERATION**
 - Cabinets
 - Cold rooms
 - Compressor racks
- **AIR CONDITIONING**
- **BMS (Building Management Systems)**



General Description

- Suited to be used when the respect of the HACCP norms requires the control of the storage goods
- Configurable analogue inputs
- Data acquisition by means of sensors with threshold controls (alarms)
- Up to 12 digital inputs for alarms, status and counters
- Pressure/temperature conversion
- Available with or without display
- Hot-Key or Prog-Tool Kit connector for quick and easy programming
- Serial connection for monitoring systems or BMS
- Up to 1, 3 or 6 available “Sections” that can have proper I/O and alarms (...see following page)



General Description

SECTIONS

It is possible to share the available I/O into subgroup named “sections” that can be 1, 3 or 6. Each section has its own ModBUS address and a certain number of inputs and outputs depending on the configuration. According to the number of configured sections, the XJM automatically shares the available resources among the sections.

Sections	Inputs	Outputs
S1	Up to 6 Probe Inputs Up to 12 Digital Inputs	Up to 4 Relay Outputs 1 x Analog Output

Sections	Inputs	Outputs
S1	Up to 2 Probes Up to 2 Digital Inputs	Up to 2 Relay Outputs 1 x Analog Output
S2	Up to 2 Probes Up to 2 Digital Inputs	1 x Relay Output
S3	Up to 2 Probes Up to 2 Digital Inputs	1 x Relay Output

Sections	Inputs	Outputs
S1	1 x Probe Input Up to 2 Digital Inputs	1 x Relay Output 1 x Analog Output
S2	1 x Probe Input Up to 2 Digital Inputs	1 x Relay Output
S3	1 x Probe Input Up to 2 Digital Inputs	1 x Relay Output
S4	1 x Probe Input Up to 2 Digital Inputs	1 x Relay Output
S5	1 x Probe Input Up to 2 Digital Inputs	
S6	1 x Probe Input Up to 2 Digital Inputs	

BMS & SUPERVISING

XJM – Multifunction inputs

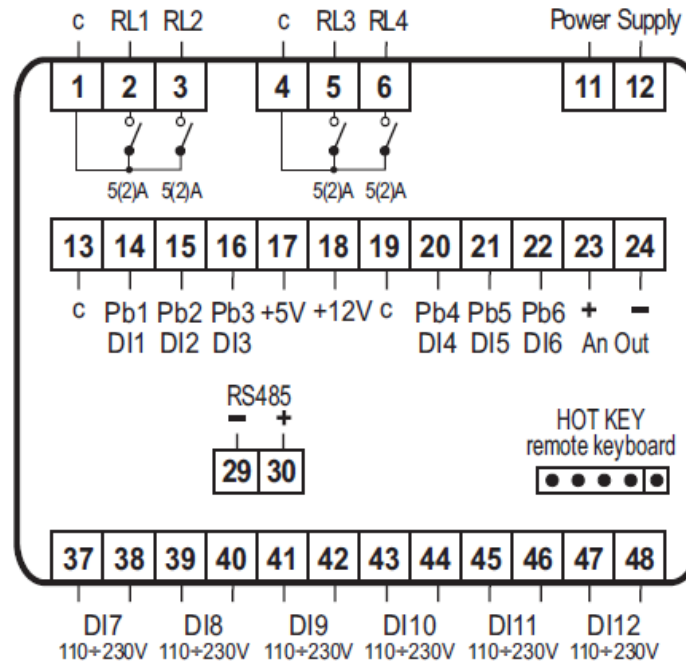

	PB1/DI1	PB2/DI2	PB3/DI3	PB4/DI4	PB5/DI5	PB6/DI6
NTC	•	•	•	•	•	•
PTC	•	•	•	•	•	•
PT1000	•	•	•	•	•	•
4-20mA	•	•	•			
0-10V	•	•	•			
0-5Vrat	•	•	•			
Dig-in	•	•	•	•	•	•
Pulse				•	•	•

BMS & SUPERVISING

XJM – Resources sharing

- **Sections management**
 - **6 – 3 – 1 Configurable Sections**
 - Every section can be singularly enabled

	Number of Sections			6 Sections				3 Sections			1 Section
I/O resources	S1	S2	S3	S4	S5	S6		S1	S2	S3	S1
Probes	PB1	PB2	PB3	PB4	PB5	PB6		PB1+PB4	PB2+PB5	PB3+PB6	All
Digital In	DI1	DI2	DI3	DI4	DI5	DI6		DI1+DI4	DI2+DI5	DI3+DI6	All
Relays	RL1	RL2	RL3	RL4				RL1+RL2	RL3	RL4	All
Analog Out	AO							AO			All

Main Configurations

The XJM can operate in 2 different modes:

- **STAND ALONE** → especially useful with a small number of users or small shops (alarm management)



- **NETWORK** → for medium-large applications also in case of retrofit (alarm management comply with HACCP regulations)



Main Configurations

STAND ALONE MODE

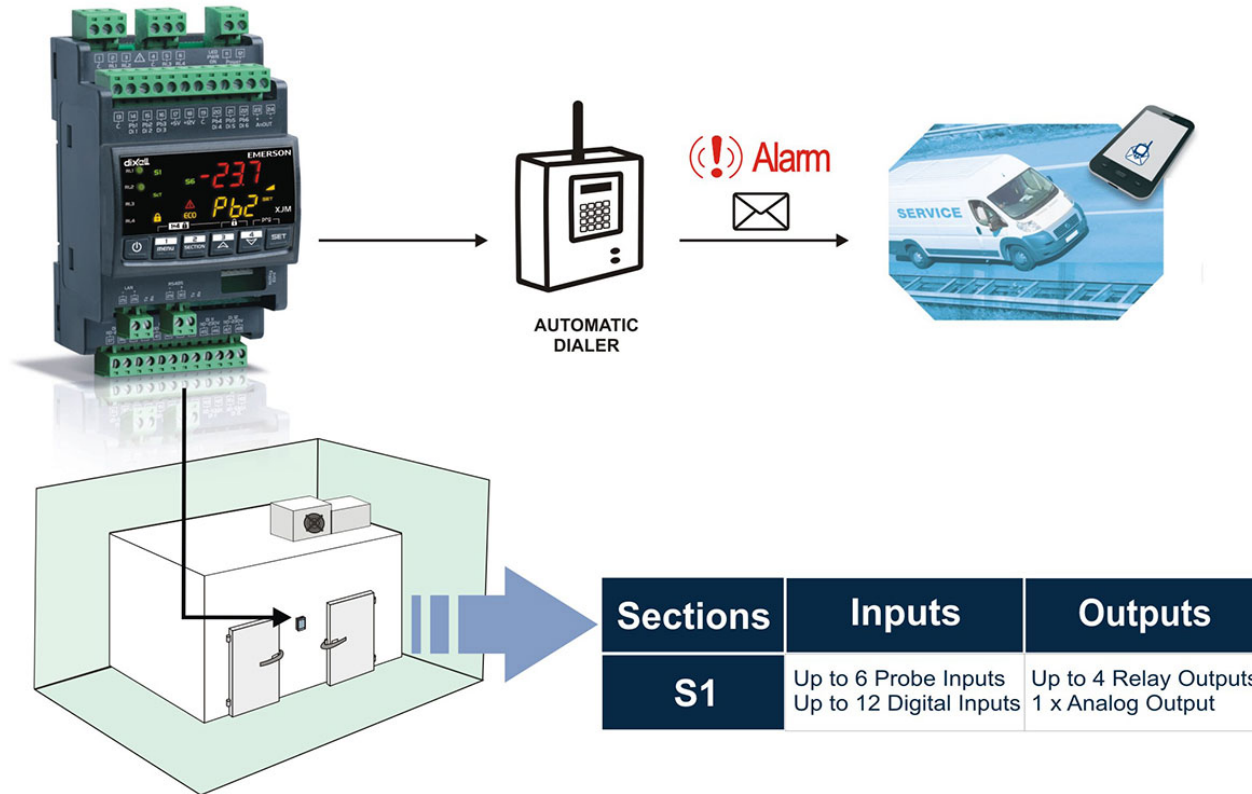

In case of any alarm, the XJM module can enable an automatic dialer which alerts a list of predefined users. The service can promptly react in order to solve the problem.

Main Configurations

NETWORK MODE (with RS485 serial port)

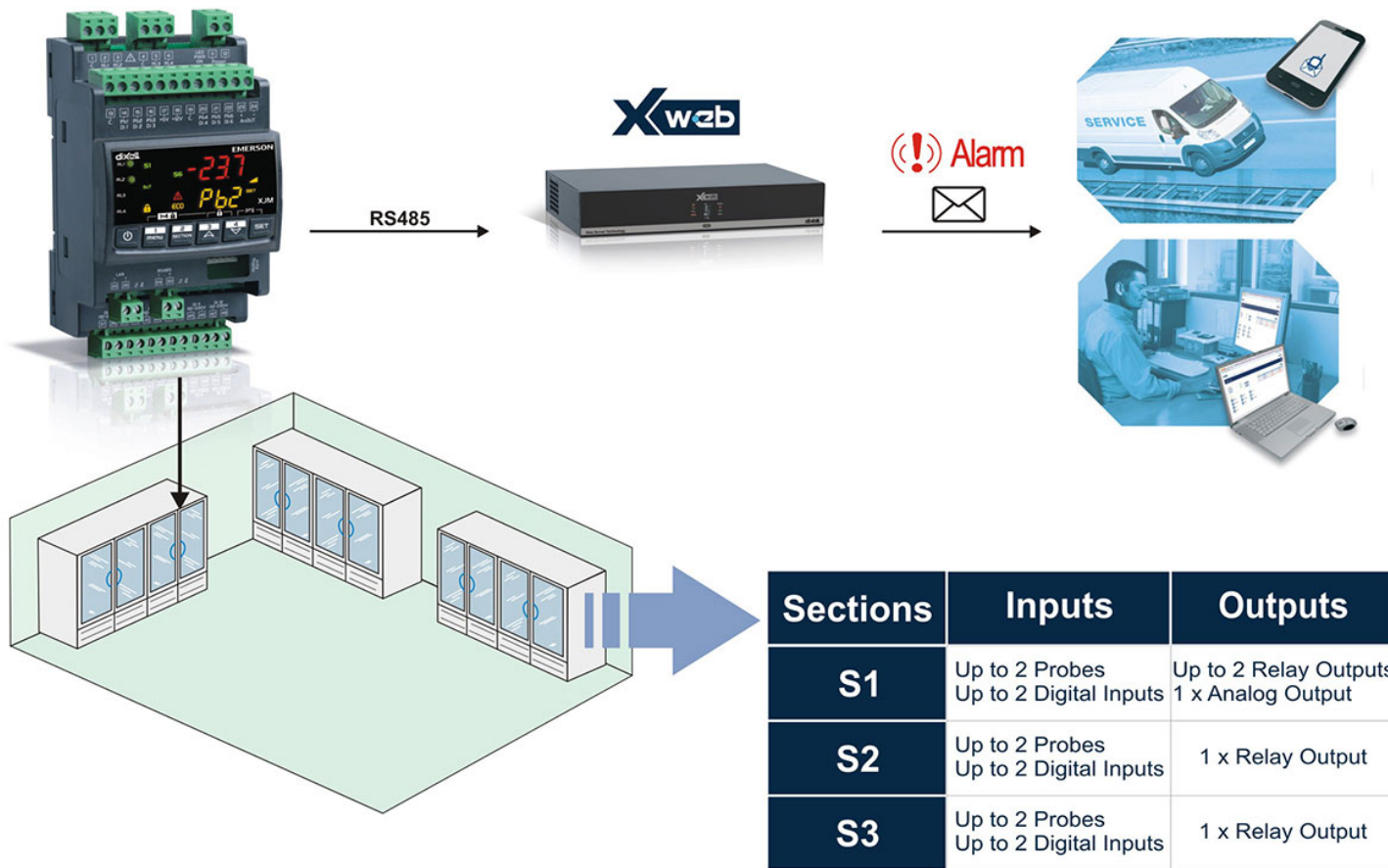

The XWEB monitoring system, through serial connection, records the values and manages any possible alarm conditions, warning the service staff that can act to solve the problem.

Main Configurations

NETWORK MODE (with wireless communication)

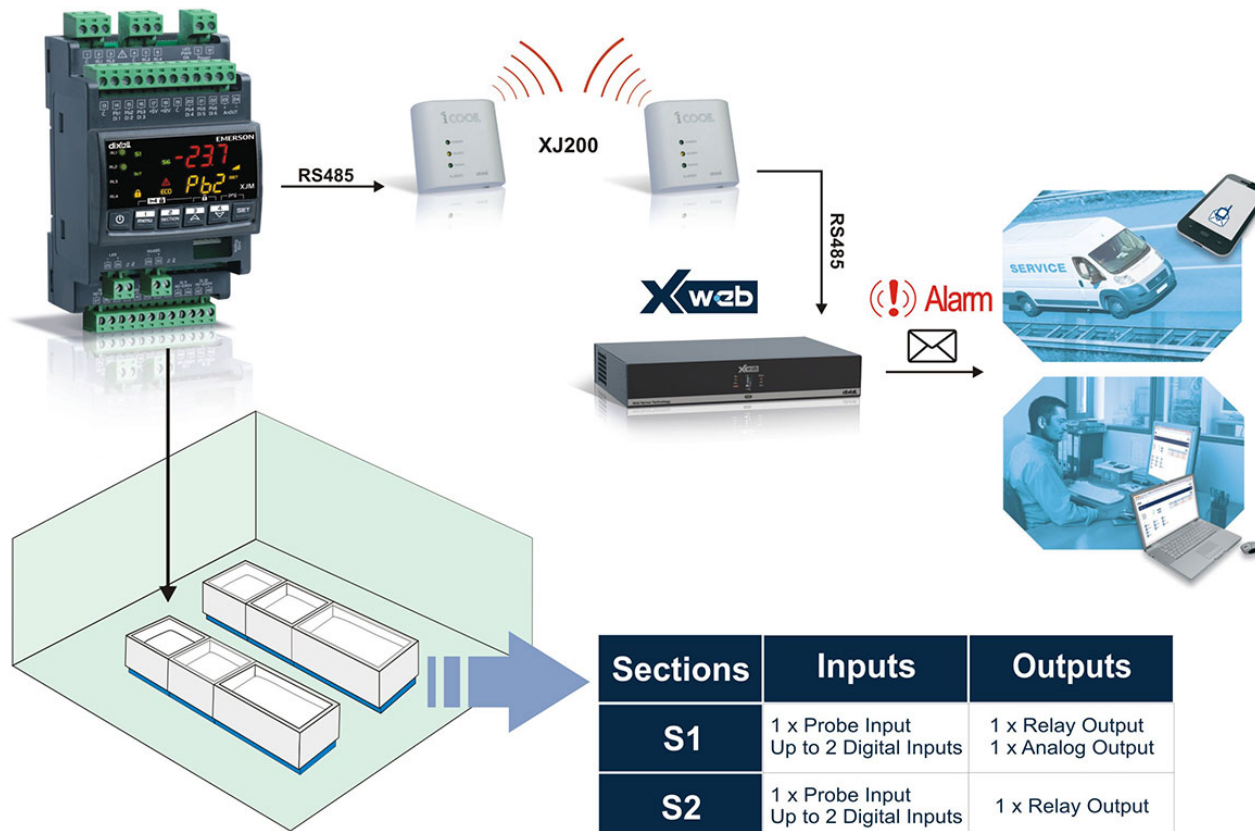

The XJM module is connected in wireless mode (through XJ200 radiofrequency modules) to the XWEB monitoring system which records the values and notifies possible alarm conditions to the service staff.

Sections	Inputs	Outputs
S1	1 x Probe Input Up to 2 Digital Inputs	1 x Relay Output 1 x Analog Output
S2	1 x Probe Input Up to 2 Digital Inputs	1 x Relay Output
S3	1 x Probe Input Up to 2 Digital Inputs	1 x Relay Output
S4	1 x Probe Input Up to 2 Digital Inputs	1 x Relay Output
S5	1 x Probe Input Up to 2 Digital Inputs	
S6	1 x Probe Input Up to 2 Digital Inputs	

Main Applications

RETROFIT and DATA ACQUISITION for COLD ROOMS

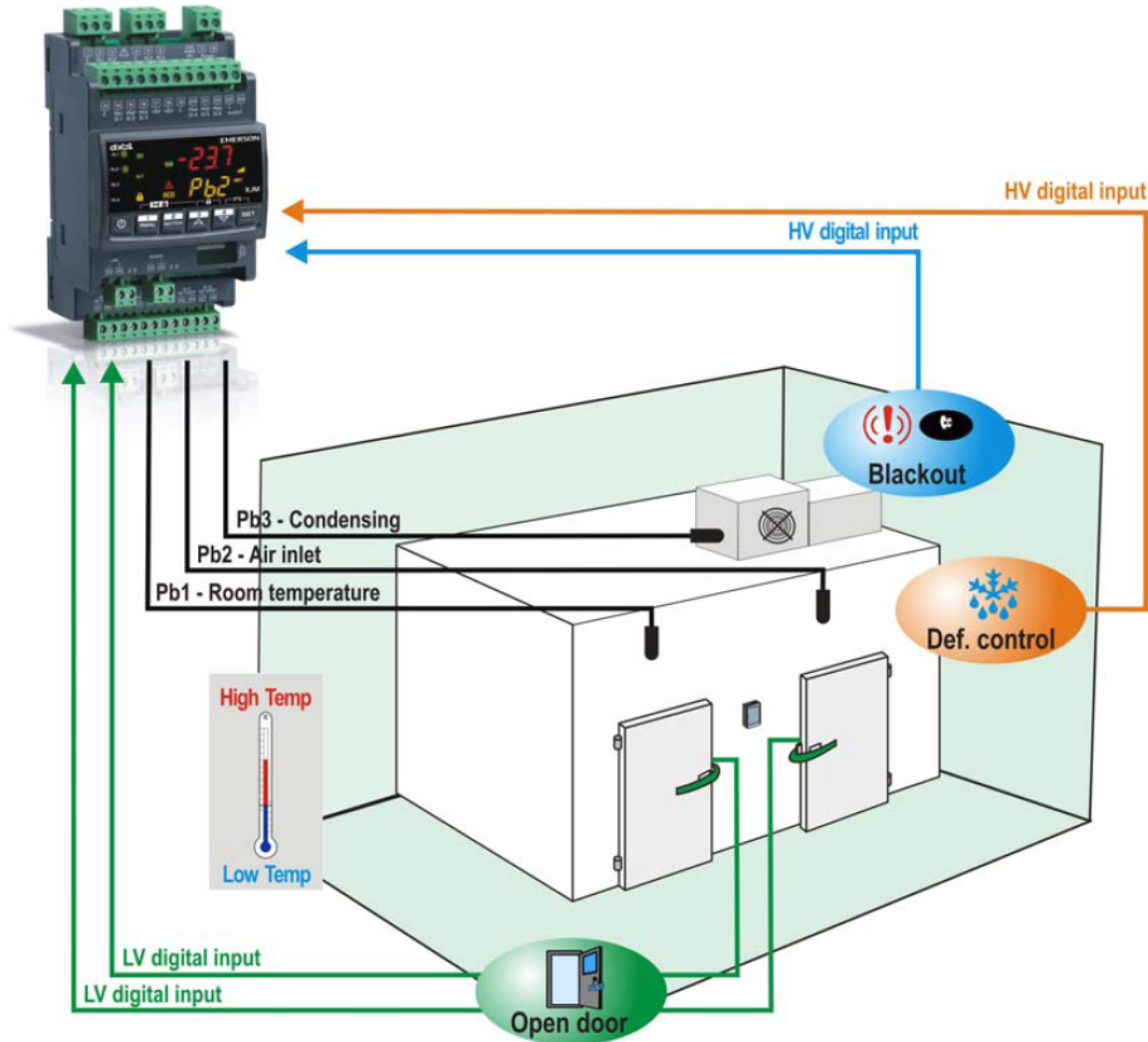

Blackout: power failure control (by using insulated digital inputs)

Defrost control: defrost duration control (by using insulated digital inputs)

Open door: open door control (by using non-insulated digital inputs)

Main Applications

RETROFIT and DATA ACQUISITION for WALL CABINETS

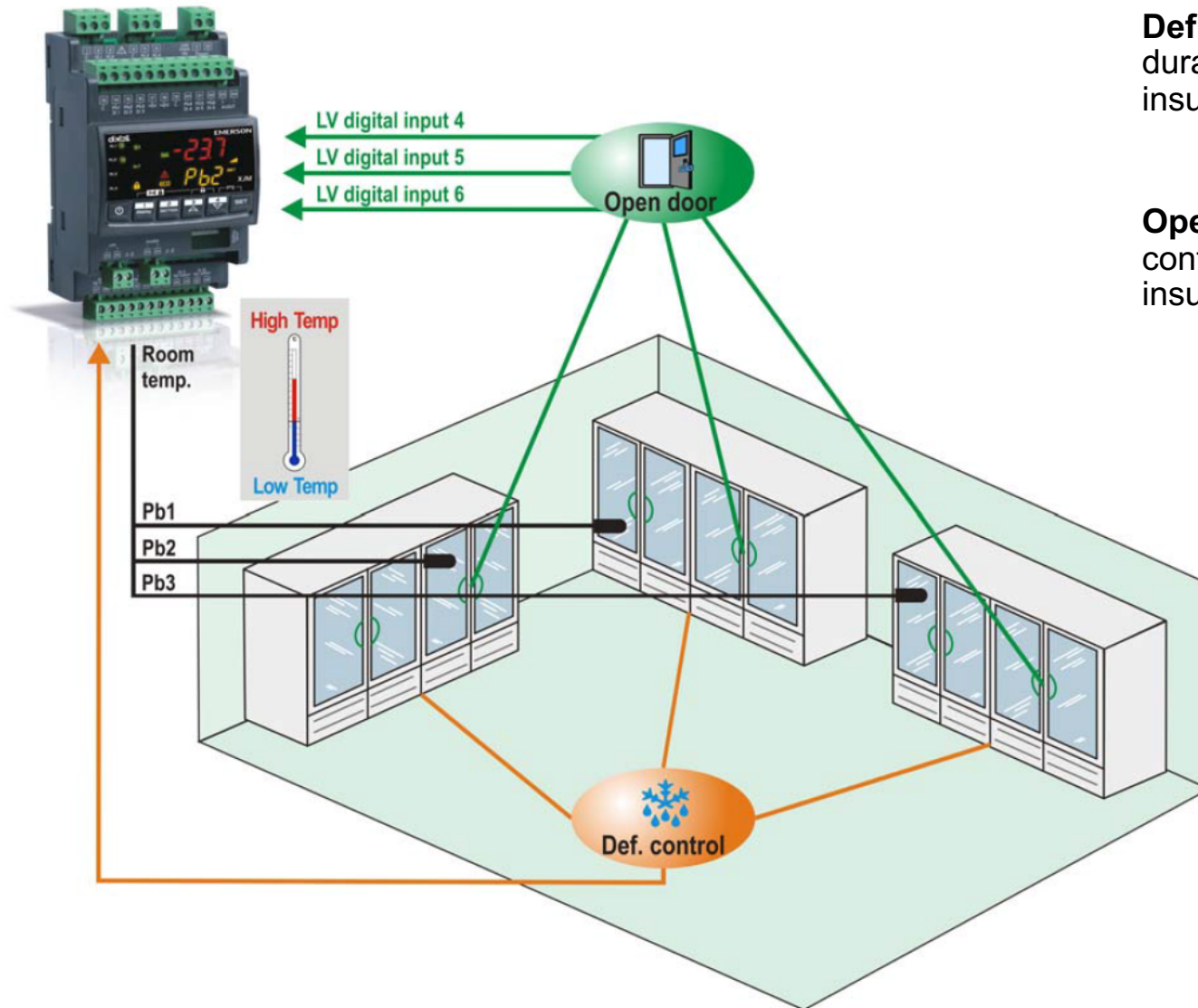

Defrost control: defrost duration control (by using insulated digital inputs)

Open door: open door control (by using non-insulated digital inputs)

Main Applications

RETROFIT and DATA ACQUISITION for PLUG-IN CABINETS

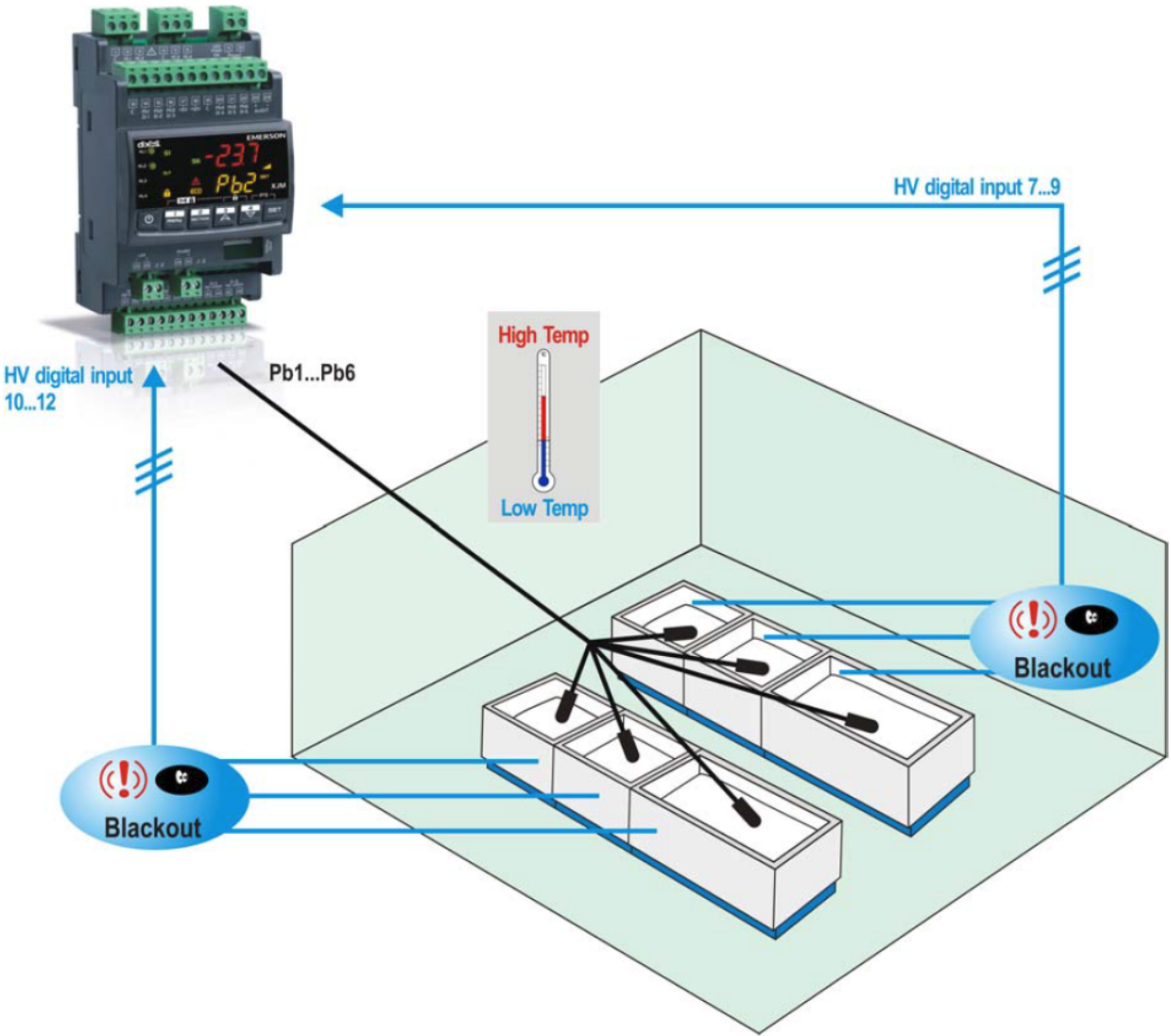

Blackout: power failure control (by using insulated digital inputs)

Main Applications

HOME AUTOMATION SYSTEM for ACCOMODATION FACILITIES (HOTEL, B&B, ...)

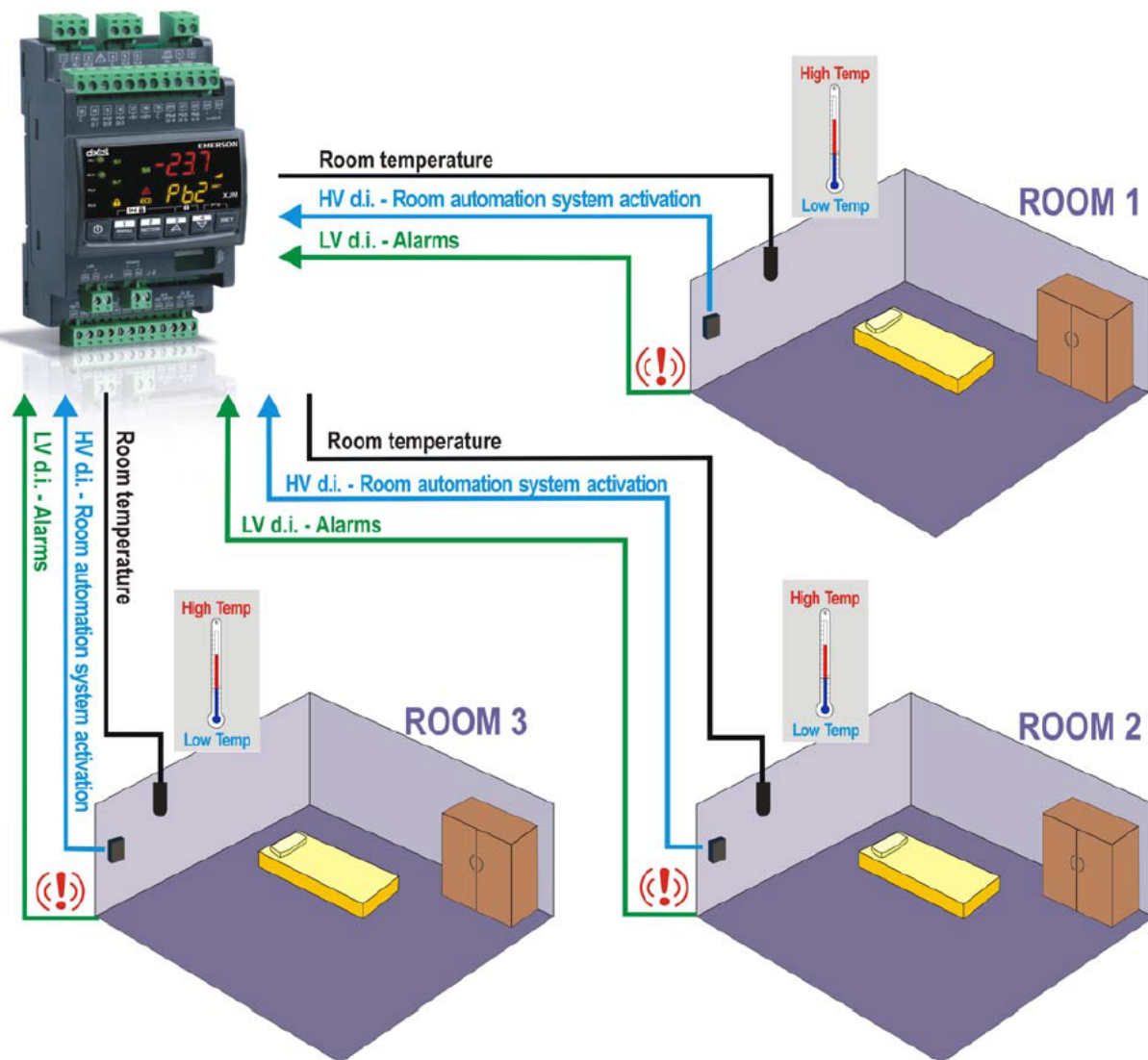

Alarms: fire, flooding, S.O.S. bathroom, open windows and more

Room automation system: lights control, TV, air conditioning system, sanitary water, connectivity and more

Main Functions

DIGITAL INPUTS

ON/OFF of the RELATED SECTION

It is possible to easily switch ON/OFF the related section by setting the parameter **Enx=YES** (x=1...6).

DIGITAL INPUT STATUS

The status of the related digital input (active/non active) can be monitored via ModBUS by setting the parameter **inx=StAt** (x=1...12).

ALARM WARNING

Alarms can be divided in different categories

DELAYED with parameter **inx=ALrd** (x=1...12);

IMMEDIATE with parameter **inx=ALr** (x=1...12);

PRESSURE SWITCH with parameter **inx=PrSA** (x=1...12).

DOOR SWITCH

The XJM module can control the door status. When the parameter **inx** (x=1...12) is configured as door and the digital input stays active for more than the **ddx** time (x=1...12), the open door alarm is generated.

Main Functions

DIGITAL INPUTS

PULSE COUNTERS

Digital inputs 3, 4 and 5 can work as counters (**inx=PUL**). If so, the XJM module will be able to display and store the number of detected pulses. There are 3 different multipliers which are used to link the correct weight to any pulse signal. **NOTE: in case of any power loss, the stored pulse counter values could be different from the real ones.**

ENERGY SAVING MODE ACTIVATION

The XJM module can operate also in energy saving mode simply using a different Set Point for the temperature control. The digital input of the related section can be activated by setting the parameter **inx=EnS** (x=1...12); this enables the energy saving mode.

DEFROST CONTROL

The device can monitor the defrost phase of the related section and its duration through the activation of the corresponding digital input by setting the parameter **inx=dFr** (x=1...12).

ON/OFF DEVICE

The device can be switched OFF enabling the digital input by setting the parameter **inx=roFF** (x=1...12). **NOTE:** only one of the 12 digital inputs has to be set as ON/OFF.

Main Functions

ANALOGUE OUTPUT

The XJM module is equipped with one analogue output which can be configured to work as 4÷20mA or 0÷10V. This output can:

- **Be remotely controlled** via ModBUS command;
- **Work as signal repeater**, connecting the output to one of the available analogue inputs (temperature, pressure probes, other analogue sensors)



Main Functions

RELAY CONFIGURATION

The XJM is provided with up to 4 configurable relays which can be activated in several modes:

- **AUTOMATICALLY:** to signal section specific or generic alarms
- **From DIGITAL INPUT:** the status of such a relay changes according to the status of the related digital input
- **REMOTELY:** directly managed by the monitoring system
- **MANUALLY:** by keyboard. This is particularly useful in case of maintenance operations



Keep pressed the MENU and DOWN keys to unlock the keyboard.

Keep pressed the MENU/1 key to enable the relay 1. Push the related key (2, 3 or 4) to enable the other relays.

Main Functions

ALARMS

Each section can have three types of alarms:

- **Low temperature**
- **High temperature**
- **Maximum temperature**



PARAMETER LIST to SET ALARMS	
Parameter (x=1...6)	Function
ALE _x	Section alarm activation
ALC _x	Absolute (Ab) and relative (rE) limits to the set point
ALU _x	Maximum temperature threshold
ALP _x	High temperature threshold
ALL _x	Low temperature threshold
AFH _x	Differential for temperature alarm recovery
Ad _x	Temperature alarm delay
dAd _x	Temperature alarm delay after a defrost phase
SPb _x	Temperature probe for the related section

Display Visualization

QUICK MENU

All the I/O values/status can be simply and quickly checked thanks to the useful XJM menu

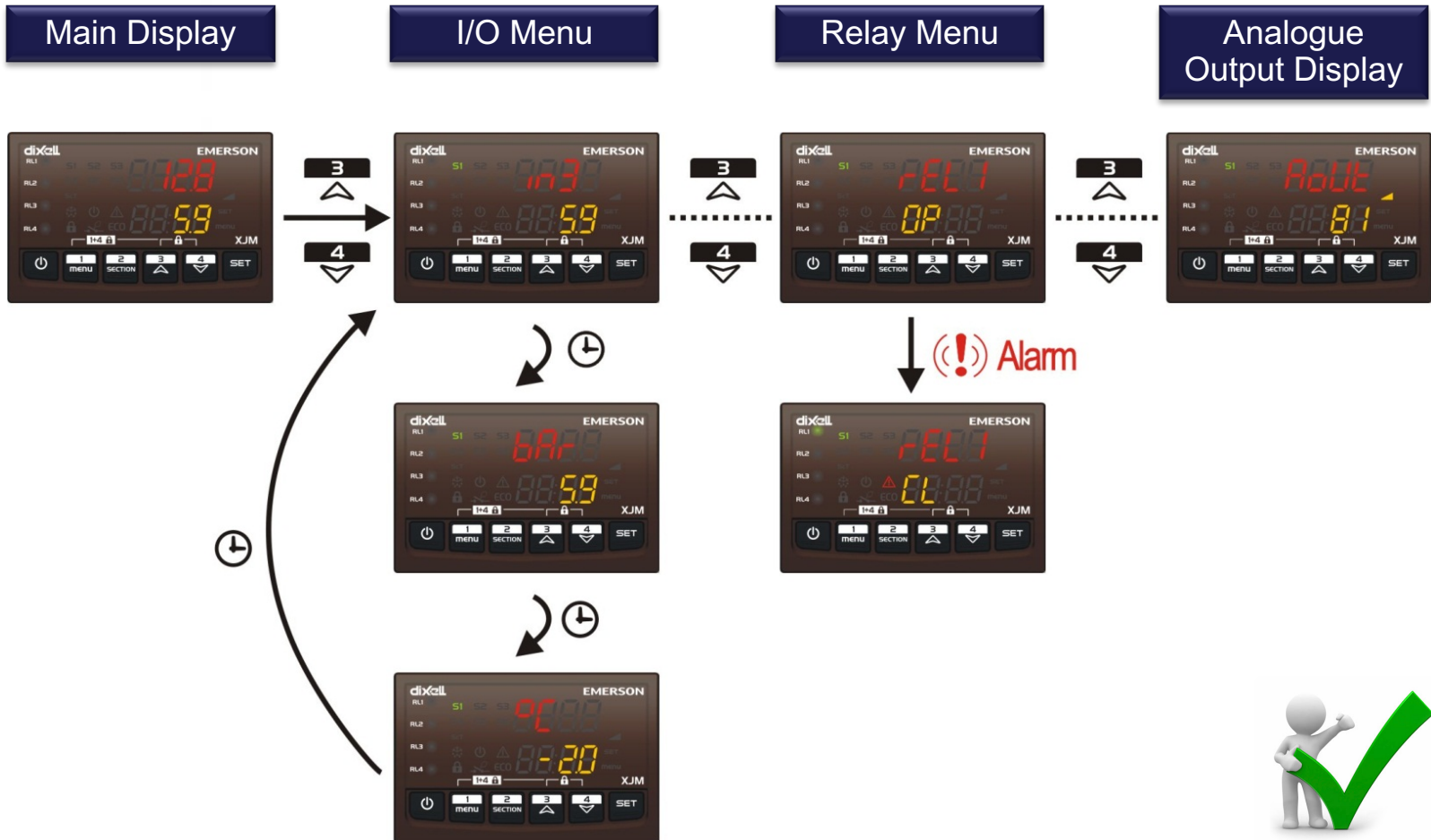

Benefits



Less Installation Costs

It is possible to monitor and control different cabinets, areas, ... in a point of sale with only one device



HACCP Extension for Existing Plants

XJM60D can be used to upgrade an existing application towards the accomplishment of the HACCP rules



High Flexibility thanks to the Wide Range of I/O Types

The XJM can be easily adapted in few minutes to any possible need; the correct I/O configuration (sensors, alarms, ...) which fits the application, can be selected in a few steps



Suitable for any Retail “Size”

Ideal for small shops as well as for medium or large supermarket applications



Family Overview

TECHNICAL FEATURES

Characteristics	XJM60D WITH DISPLAY	XJM60D WITHOUT DISPLAY
First display	4 d.p.	
Second display	4 d.p.	
Dimensions	4DIN	4DIN
Keyboard	6 keys	
Remote keyboard		VJM60 (6 keys)
Power supply	24Vac	24Vac
Analogue inputs (*)	Up to 6 probes NTC, PTC, PT1000, 4÷20mA, 0÷5V, 0÷10V	Up to 6 probes NTC, PTC, PT1000, 4÷20mA, 0÷5V, 0÷10V
Digital inputs (*)	Up to 6 free of voltage and 6 power supply voltage contacts	Up to 6 free of voltage and 6 power supply voltage contacts
Relay output	1 or 4 x 5A	1 or 4 x 5A
Hot-Key / Prog-Tool Kit	Present	Present
Analogue output	4÷20mA or 0÷10V	4÷20mA or 0÷10V
Serial output	RS485	RS485

(*) Main examples of probe configuration:

- 6 temperature probe + 6 insulated digital inputs
- 3 temperature probe + 3 non-insulated digital inputs + 6 insulated digital inputs
- 3 pressure probe + 3 temperature probe + 6 insulated digital inputs
- 3 temperature probe + 3 pulse inputs + 6 insulated digital inputs

Family Overview

WIRING DIAGRAM

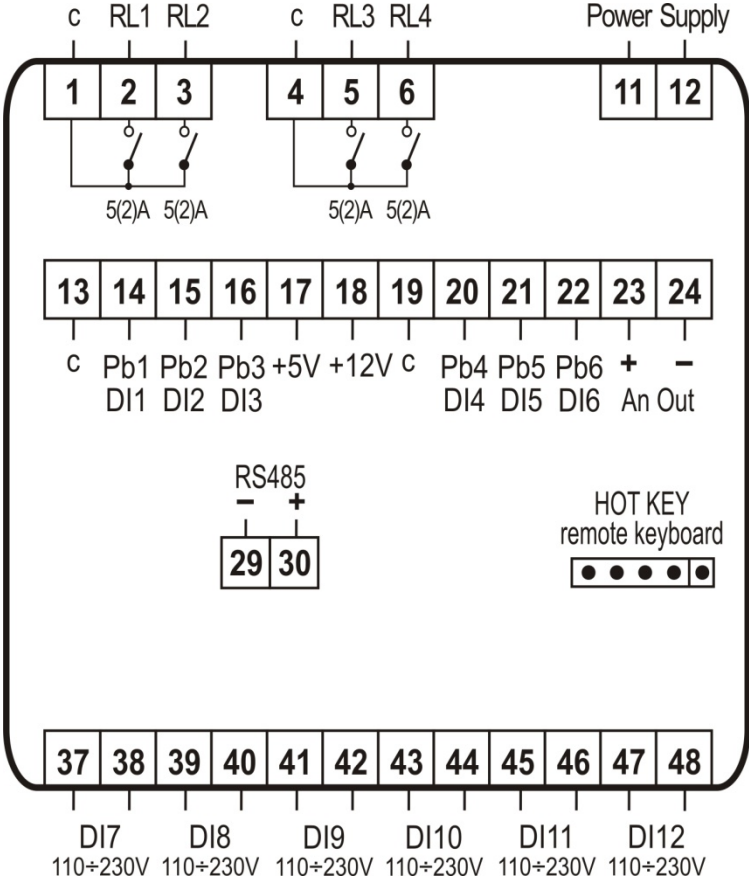

Family Overview

DIMENSIONS

4 DIN RAIL Format

Wall or DIN Rail mounting

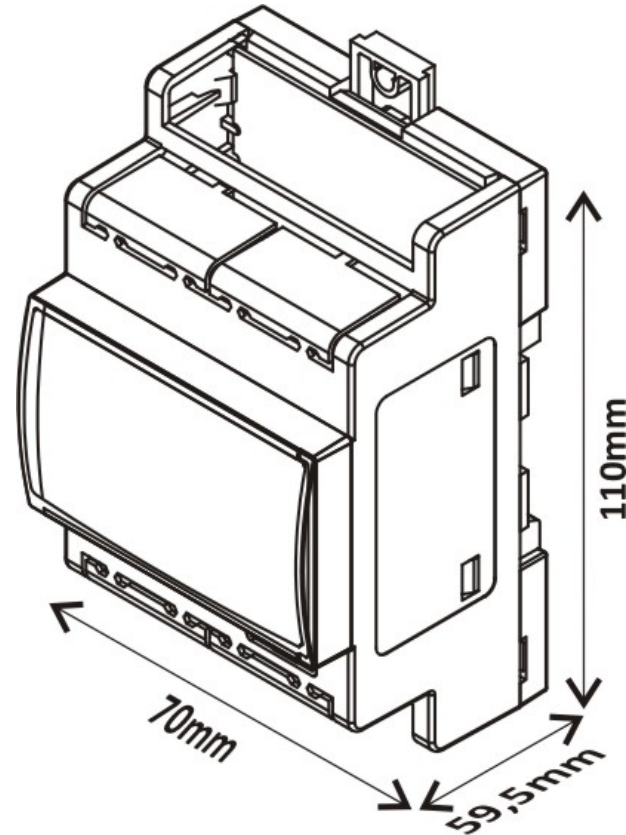

Family Overview

ACCESSORIES, PROGRAMMING



HOT-KEY

Key for a quick and easy upload (from device to HOT-KEY) or download (from HOT-KEY to device) of the parameter map



VJM60

The XJM module without display can be connected to the VJM60 keyboard with 6 keys, dual display and 4 digits with D.P., that allows a direct access to the main functions