

O P E R A T I N G M A N U A L



Vortex[®] Dual

Refrigerant Recovery Machine

English · Español · Français · Deutsch · Italiano · Nederlands · Svenska · 中文



Table Of Contents

English

Vortex Dual Operating Manual 3

Español

Manual de funcionamiento de Vortex Dual 18

Français

Manuel d'utilisation Vortex Dual 35

Deutsch

Vortex Dual Betriebsanleitung 52

Italiano

Manuale Operativo Vortex Dual 69

Nederlands

Bedieningshandleiding voor Vortex Dual 86

Svenska

Användarhandbok för Vortex Dual 103

中文

Vortex Dual 操作手册 119

Table Of Contents

Safety First!	4
Product Safety	4
Responsibility	4
Trademarks	4
EPA Certification	5
Declaration of Conformity	5
1.0 Safety Precautions	6
2.0 Specifications, Features and Warranty	7
2.1 Vortex Dual Specifications	7
2.2 Warranty	8
3.0 Setup and Operation	8
3.1 Getting Started	8
3.2 Standard Recovery Operation	10
3.3 Purging Vortex Dual	11
3.4 Push-Pull Operation	12
3.5 Cooling The Recovery Tank	13
3.6 Special Operating Notes	14
4.0 Maintenance	14
5.0 Troubleshooting	14
6.0 Service	15
7.0 EPA Requirements (PN 714-202-G1 only)	16

Thank you for buying the INFICON Vortex® Dual Refrigerant Recovery Machine! For optimal Vortex Dual performance, read this manual carefully before use.

For additional questions or assistance, contact INFICON.

USA: +1.800.344.3304 or service.tools@inficon.com

Europe: +49 221 56788-660 or servicetools.europe@inficon.com

Safety First!



This symbol is intended to alert the presence of critical items regarding operating, safety and maintenance (servicing) instructions in this manual.

Product Safety

Vortex Dual is a recovery machine for a broad range of refrigerants. Recovering refrigerants into separate storage tanks involves a process of gas compression, resulting in high pressures within the machine, the connecting hoses, and the storage tank.



High pressure systems can cause accident or injury if not handled properly, and with care.

Refrigerant hoses must have shut-off devices within 30.5 cm (12 in.) of the ends, to reduce the likelihood of refrigerant leakage to the atmosphere when changing tanks or setups.

Responsibility



Do not use Vortex Dual unless properly trained in the recovery process. Operation of this machine by unqualified personnel is potentially dangerous.

Trademarks

The trademarks of the products mentioned in this manual are held by the companies that produce them.

Vortex®, Compass®, D-TEK® Select, TEK-Mate®, and Wey-TEK™ are trademarks of INFICON.

All other brand and product names are trademarks or registered trademarks of their respective companies.

The information contained in this manual is believed to be accurate and reliable. However, INFICON assumes no responsibility for its use and shall not be liable for any special, incidental, or consequential damages related to the use of this product.

© 2016 All rights reserved.

Reproduction or adaptation of any part of this manual without permission is unlawful.

EPA Certification

INFICON Vortex Dual (PN 714-202-G1 only) is an EPA Certified machine in accordance with Section 608 of the Clean Air Act. It has been independently tested and certified to conform with AHRI standard 740.



EU Declaration of Conformity

This declaration is issued under the sole responsibility of the manufacturer INFICON. The object of the declaration is to certify that this equipment, designed and manufactured by INFICON, is in conformity with the relevant Community harmonization legislation. It has been constructed in accordance with good engineering practice in safety matters in force in the Community and does not endanger the safety of persons, domestic animals or property when properly installed and maintained and used in applications for which it was made.

Equipment Description	Vortex Dual Refrigerant Recovery Machine
Model Number	714-202-Gxx (Applicable to all Group numbers)
Applicable Directives	2014/35/EU (LVD) 2014/30/EU (EMC) 2011/65/EU (RoHS)
Applicable Standards	EN 60335-1:2012/A11:2014 EN 55014-1:2006/A2:2011 / CISPR14-1:2005/A2:2011 EN 50581:2013
CE Implementation Date	April 20, 2016

Manufacturer Representative
 Brian King
 INFICON
 Business Line Manager – Service Tools
 Two Technology Place
 East Syracuse, NY USA 13057

EU Authorized Representative
 INFICON GmbH
 50968 Köln, Bonner Str. 498

Any questions relative to this declaration or to the safety of INFICON's products should be directed, in writing to the quality assurance department at the above address.

1.0 Safety Precautions

Read this manual before using Vortex Dual to become familiar with its specifications and operation. Review the Material Safety Data Sheets (MSDS) and the Temperature - Vapor Pressure information for the proper safety and handling requirements regarding the refrigerants being recovered.



Wear gloves, eye protection and foot protection when working on refrigeration systems.



Refrigerant vapor can be hazardous and its by products can be lethal.



Motors and switches can generate sparks and can be especially dangerous in flammable environments. Work only in well-ventilated areas, with mechanical ventilation that provides at least four air change rates per hour. Do not work in an enclosed area without appropriate safety equipment. It may be necessary to install a separate circulation fan.



Never use oxygen for leak detection. Oxygen can become an explosive mixture in the presence of oil and pressure. Perform leak detection in accordance with recommended practice only. For best results, use a refrigerant detector, such as INFICON D-TEK Select, Compass, or TEK-Mate.



Never mix refrigerants. Use separate storage cylinders, hoses, and filters for each type of refrigerant recovered. Store refrigerants in a cool, dry place.



Never overfill a storage container. Overfilled tanks can rupture and explode. Use a refrigerant scale such as INFICON Wey-TEK to prevent overfill.



When opening service or cylinder valves, do so slowly, to ensure all connections are secure and free of danger.



Disconnect power before moving or servicing Vortex Dual.





The risk of electric shock and exposure to hot compressor parts is possible if the Vortex Dual covers are removed. Vortex Dual should only be opened by a qualified technician who has been trained in basic electronics and refrigeration.



Use only the power cord supplied by INFICON. If the cord is lost or damaged, contact INFICON for information on obtaining a replacement.

 When connected to Vortex Dual, extension cord wiring can overheat under conditions of high current draw. If an extension cord is necessary, use the shortest possible length and only size 14 AWG or larger for 115 V (ac) or 1.00 mm² or larger for 230 V (ac).

 Do not use Vortex Dual near open containers of gasoline or other flammable liquids.

 This product is designed for use with refrigerants only and is not intended for use with any combustible refrigerants. Any other uses of this product are not recommended by INFICON and could result in personal injury. Use of this product other than intended is done at the user's own risk.

2.0 Specifications, Features and Warranty

2.1 Vortex Dual Specifications

Refrigerants	R-12, R-1234yf, R-134a, R-22, R-401A, R-401B, R-401C, R-402A, R-402B, R-404A, R-407A, R-407B, R-407C, R-408A, R-409A, R-410A, R-500, R-502, R-507
Power	115 V (ac), 60 Hz, 12 A, or 230 V (ac), 50/60 Hz, 10A (depending on version)
Protection	High pressure switch cutoff at 550 PSI, 3.8 MPa, 38 bar Compressor motor thermally protected
Pressure	Low side design pressure 350 PSI, 2.4 MPa, 24 bar High side design pressure 550 PSI, 3.8 MPa, 38 bar
Temperature	Operating range 10 to 40°C (50 to 104°F)
Pollution degree	2
Ingress protection	IP20
EPA Certification (PN 714-202-G1 only)	Certified for all refrigerants listed under categories III, IV, & V in ARI standard 740-1998

2.2 Warranty

INFICON warrants the Vortex Dual Refrigerant Recovery Machine to be free from defects of materials or workmanship for three years from the date of purchase. INFICON does not warrant any machine that has been subjected to misuse, negligence, or accident, or has been repaired or altered by anyone other than INFICON.

The compressor is warranted for a period of three years by the manufacturer. To keep this warranty in force, a filter (included) must be used on the inlet port or hose at all times to prevent particulates from entering the compressor. *Failure to use the included filter will void the compressor warranty.*

INFICON liability is limited to repairing or replacing, at its option, a defective machine or part. If a defect arises, a valid claim must be received by INFICON, with transportation prepaid, no later than thirty (30) days after the warranty period expires. INFICON will determine whether the machine has malfunctioned due to defective materials or workmanship.

This warranty is in lieu of all other warranties, expressed or implied, whether of merchantability, fitness for a particular purpose, or otherwise. All such other warranties are expressly disclaimed.

INFICON shall have no liability in excess of the price paid to INFICON for Vortex Dual, plus return transportation charges prepaid. INFICON shall have no liability for any incidental or consequential damages. All such liabilities are excluded.

3.0 Setup and Operation

3.1 Getting Started

Review the full contents of this manual before operating Vortex Dual.



Failure to follow proper safety precautions can result in personal injury or death. Do not use Vortex Dual unless properly trained in the recovery process.

- 1 Install the included filter on the inlet. Vortex Dual has a female refrigerant flare fitting, and connects with male flare fittings.
- 2 Attach the hoses to the filter.



Do not use an adapter fitting in place of a filter. Use of an adapter fitting can damage the valves and will void the warranty.

- 3 Attach a hose from the discharge valve to the recovery tank. Connect other hoses between system components, according to [Figure 1 on page 10](#).

- 4** Connect the AC power cord to a circuit protected by an appropriately sized circuit breaker. If an extension cord is absolutely necessary, make sure it meets the following conditions:
- ♦ length is not excessive
 - ♦ contains a safety ground wire
 - ♦ wire size 14 AWG or larger for 115 V (ac) or 1.0 mm² or larger for 230 V (ac)



Overfilled tanks can rupture and explode. When operating in standard recovery or push-pull mode, it is possible to overfill the tank. Use a refrigerant scale to ensure that the tank does not exceed 80% of its capacity, by weight. Check the tank weight before transporting.



Do not allow Vortex Dual to recover large amounts of liquid too quickly.

NOTE: When a significant amount of liquid is present and enters the recovery machine too quickly during the refrigerant recovery process, this is sometimes referred to in the field as a "liquid slug" or "slugging."

A liquid slug can activate the High Pressure shutoff and prolong the refrigerant recovery process. If Vortex Dual recovers large amounts of liquid too quickly (or a liquid slug is present), a loud knocking will sound from the compressor.



Compressor damage caused by recovering a large amount of liquid too quickly is not covered by the compressor warranty.

Monitor the recovery process carefully. If the compressor begins to knock:

- ♦ throttle the **INLET** valve clockwise, or
- ♦ adjust the **MANIFOLD** gauge valves until the knocking stops.

3.2 Standard Recovery Operation

- 1 Connect all cables and hoses as described in [section 3.1](#).

NOTE: Make sure all connections are tight, and that the cables and hoses do not interfere with recovery process. See [Figure 1](#).

Figure 1 Setup procedure for standard refrigerant recovery

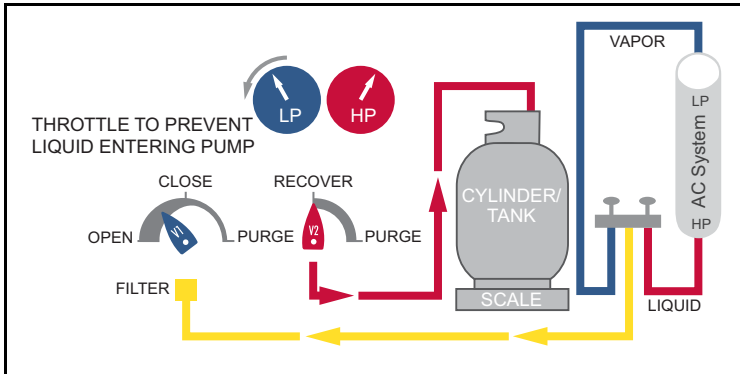

- 2 Make sure the hose connecting Vortex Dual to the recovery tank is attached to the **LIQUID** port (LP).
- 3 **OPEN** the LP valve on the tank. Keep the **VAPOR** port **CLOSED**.
- 4 Rotate the INLET valve (V1) to **CLOSE**.
- 5 Set the PURGE/RECOVER valve (V2) to the **RECOVER** position.
- 6 Slowly rotate the **LIQUID** valve on the MANIFOLD gauge set to **OPEN**. Make sure there are no leaks.
- 7 Turn on Vortex Dual.
- 8 Monitor the inlet pressure (LP, Low Pressure gauge) and *slowly* rotate the INLET valve (V1) to **OPEN**.

 The compressor may emit a knocking sound if Vortex Dual attempts to recover a significant amount of liquid. To prevent damage to the compressor, throttle the **LIQUID** valve on the MANIFOLD gauge set, or the Vortex Dual INLET valve (V1).
- 9 Once the liquid has been recovered, transfer the remaining vapor; rotate the INLET valve (V1) to **OPEN**. Make sure the **LIQUID** and **VAPOR** valves on the MANIFOLD gauge are **OPEN**.

10 Continue to operate until the **LP** gauge indicates the required vacuum has been obtained.

11 Turn off Vortex Dual and close the **INLET** valve (**V1**). Wait five minutes.

If the **MANIFOLD** gauge indicates pressure has risen above **0 PSIG** (0 bar), refrigerant is still present.

- ♦ Open the **INLET** valve (**V1**) and turn on Vortex Dual.
- ♦ Run Vortex Dual until the required vacuum is reached again.
- ♦ Wait five minutes. Repeat this process until all refrigerant is removed and pressure is **0 PSIG** (0 bar), or less.

12 Immediately purge Vortex Dual. Purging is necessary to remove any residual refrigerant from inside Vortex Dual internal components as well as the hose from the outlet to the recovery tank. See [section 3.3](#).

3.3 Purging Vortex Dual

- 1** While Vortex Dual is off, rotate the **PURGE/RECOVER** valve (**V2**) to **PURGE**. See [Figure 2](#).
- 2** Turn on Vortex Dual and *slowly* rotate the **INLET** valve (**V1**) to **PURGE**.
- 3** Run Vortex Dual and monitor the **LP** gauge until a vacuum of **20 In/Hg** (0.7 bar) or more is achieved.
- 4** Turn off Vortex Dual and *immediately* close the valves on the recovery tank. Rotate the inlet valve (**V1**) to **CLOSE**.

 The hose and the discharge port will contain a small amount of pressurized refrigerant. Exercise care when removing this hose.

Figure 2 Setup procedure for purging



3.4 Push-Pull Operation

The push-pull recovery method is used to move large amounts of liquid refrigerant. During this process, the recovery unit pulls vapor from the recovery cylinder and produces high pressure discharge gas that pushes liquid out of the HVAC system and back into the recovery cylinder. Recovery rates above 15 pounds per minute can be achieved when using this procedure.

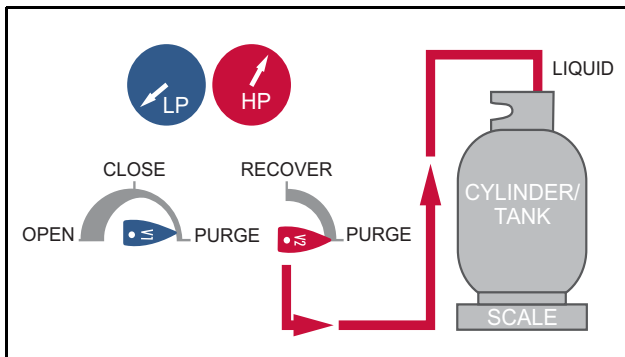
NOTE: Do not attempt the push-pull process unless the system contains at least 15 pounds (7 Kg) of liquid that can easily be isolated.

To prevent overfill, use the scale to make sure the tank does not surpass 80% capacity, by weight. Monitor the tank weight carefully as 80% capacity may be reached quickly during push-pull due to its rapid transfer.

Connect the refrigerant hoses (see [Figure 3](#)). A sight glass, not included, can help determine when the liquid has been transferred and vapor remains.

Figure 3 Setup procedure for push-pull method

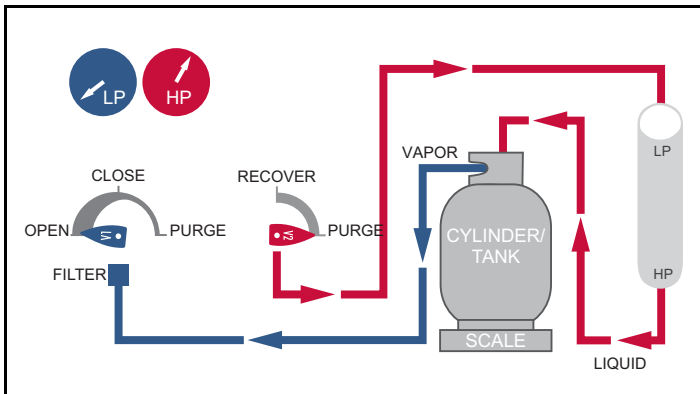

3.5 Cooling The Recovery Tank

Vortex Dual can be used to pre-cool (or sub-cool) the recovery tank, if the head pressure is too high to complete the recovery process. If the ambient pressure is too high, high head pressure can occur when working with certain refrigerants that have a high vapor pressure.

NOTE: The recovery tank must contain five pounds or more of liquid, to allow the pressure differential to develop.

Sub-cooling the tank before starting the recovery process may provide little or no benefit.

If the recovery process stalls because of high head pressure, turn off Vortex Dual, close the hose valves, and reconfigure the setup as shown in [Figure 4](#).

Figure 4 Setup procedure for sub-cooling method

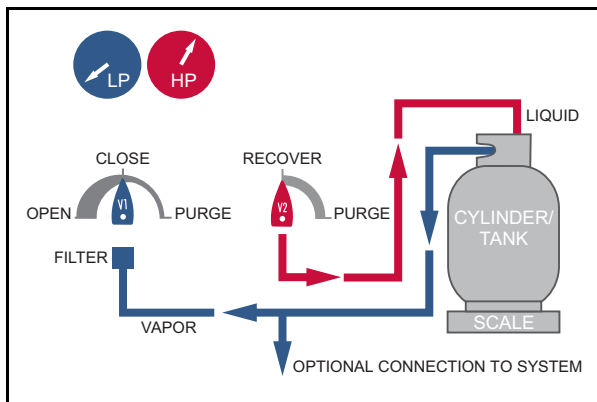

- 1 Rotate **V2** on the Vortex Dual to **RECOVER** and open the **LIQUID** and **VAPOR** valves on the cylinder.
- 2 Turn on Vortex Dual.
- 3 Rotate **V1** on Vortex Dual to **OPEN**.
- 4 On the cylinder, throttle the flow of liquid by slowly closing the **LIQUID** valve to achieve a minimum pressure differential of **100 PSIG** (0.7 MPa, 7 bar) between the LP and the HP gauges.

NOTE: To prevent the HP cutoff switch from actuating, do not allow the HP gauge to exceed **550 PSIG** (3.8 MPa, 38 bar).

- 5 Once the recovery tank is cold, turn off Vortex Dual and reconfigure the setup for standard recovery. Repeat as needed.

3.6 Special Operating Notes

During standard operation, the High Pressure switch will reset when the head pressure drops below approximately 425 PSI (2.9 MPa, 29 bar), and Vortex Dual will restart automatically.

4.0 Maintenance

With minimal but important maintenance, Vortex Dual can provide many seasons of reliable service. After each use, clean Vortex Dual with a damp cloth to remove dirt and oils.



Do not use gasoline or other hazardous solvents to clean Vortex Dual; this can damage the plastic enclosure. Standard household detergent or isopropyl alcohol may be used, but do not allow liquid to penetrate the outer case.

Make sure the inlet and discharge ports are protected during transit and storage; keep the inner diameter and the outer threads clear and clean.

NOTE: For best results, leave the filter connected to the inlet port, and change the filter regularly.

5.0 Troubleshooting

PROBLEM	CAUSE	ACTION
Vortex Dual will not turn on; compressor does not start	<ol style="list-style-type: none"> 1. Power cord is not attached 2. No voltage at receptacle 3. Circuit breaker has opened 4. Discharge pressure is too high; HP switch has opened 5. Electronics failure in motor 	<ol style="list-style-type: none"> 1. Attach power cord 2. Verify voltage at job site 3. Identify cause of breaker activation, rectify and reset 4. Reduce pressure; rotate V2 to Purge, then back to Recovery 5. Factory service required
Compressor starts, but falters within minutes; pressure indication on HP gauge is high	<ol style="list-style-type: none"> 1. Recovery tank valve is not open 2. Discharge hose blocked 3. Air in system/tank 	<ol style="list-style-type: none"> 1. Open tank valve 2. Check and clear blockage 3. Bleed air from system/tank

PROBLEM	CAUSE	ACTION
Compressor stops intermittently	<ol style="list-style-type: none"> 1. Vapor pressure of refrigerant in tank is close to HP trip point 2. Thermal overload switch in compressor is activating 	<ol style="list-style-type: none"> 1. Reduce tank temperature 2. Reduce amount of liquid being pumped; let machine cool before proceeding
Vortex Dual overheats	<p>Excessive head pressure, due to:</p> <ol style="list-style-type: none"> 1. High ambient temperature 2. Restricted discharge hose 3. Air in recovery tank 	<ol style="list-style-type: none"> 1. Reduce tank temperature 2. Check and clear restriction 3. Bleed air from tank
Recovery process too slow	<ol style="list-style-type: none"> 1. Head pressure is too high 2. System refrigerant is frozen 3. Compressor seals are worn 	<ol style="list-style-type: none"> 1. Reduce tank temperature or change tanks 2. Interrupt process to allow ice to dissipate 3. Rebuild compressor with service kit — contact wholesaler for assistance

6.0 Service

Vortex Dual uses electrical components recognized by international safety agencies or components that have been specially designed for this application.



Do not change any of these components, as it could compromise safety. All service work must be performed at an INFICON-approved facility to maintain the safety rating and the warranty.

If defective, do not return Vortex Dual directly to the factory. For technical assistance or service information, contact INFICON or your wholesaler.

7.0 Replacement Parts and Accessories

The following parts and accessories are available through many distributors. Contact INFICON or your local distributor for availability.

Power cord (115 V)	068-0684
Power cord (230 V)	068-0685
Low pressure gauge	722-406-P1
High pressure gauge.	722-407-P1
Carrying strap	722-408-P1
Filter dryer (1/4 in. male to male)	722-409-P1

8.0 EPA Requirements (PN 714-202-G1 only)

Under Section 608 of the Clean Air Act (40 CFR Part 82), the Environmental Protection Agency (EPA) has established regulations that cover all aspects of the refrigerant recovery process.

These regulations have established service practices that maximize the recycling of ozone-depleting compounds during the servicing and disposal of air-conditioning and refrigeration equipment.

Certification requirements for recovery equipment and technicians have also been established. The INFICON Vortex Dual has been EPA Certified for use by an independent laboratory.

The EPA has also established Evacuation Requirements for HVAC/R equipment used for service, to ensure that any release of CFCs or HCFCs to the atmosphere is minimized.

- ◆ Technicians repairing small appliances such as household refrigerators, window air conditioners and water coolers, must recover 80% of the refrigerant when the compressor in the appliance is not operating.
- ◆ Technicians repairing small appliances must recover 90% of the refrigerant when the compressor in the appliance is operating.

NOTE: These requirements may also be met by evacuating the small appliance with the recovery machine to four inches of mercury vacuum.

Other requirements are covered in [Table 7-1](#).

Table 7-1 EPA Requirements

TYPE OF APPLIANCE	REQUIRED INCHES OF HG VACUUM
HCFC-22 appliance generally containing less than 200 pounds of refrigerant	0
HCFC-22 appliance generally containing 200 pounds or more of refrigerant	10
Other high pressure appliance generally containing less than 200 pounds of refrigerant	10
Other high pressure appliance generally containing 200 pounds or more of refrigerant	15
Very high pressure appliance (CFC-13, -503)	0
Low Pressure appliance (CFC-11, HCFC-123)	25*

*mm Hg absolute

The EPA requires that service technicians certify the acquired recovery equipment to the appropriate EPA Regional Office, and that it is in compliance with the applicable laws established by the Clean Air Act. Forms are available from the Regional Office of the EPA.

Questions about the EPA requirements can be answered by contacting the Ozone Protection Hotline, toll free, at +1.800.296.1996.



Bonner Strasse 498
D-50968 Cologne, Germany

Phone: +49 221 56788-660
Fax: +49 221 56788-9660
E-Mail: servicetools.europe@inficon.com
www.inficonservicetools.com

Two Technology Place
East Syracuse, NY 13057-9714 USA

Phone: +1.800.344.3304
Fax: +315.437.3803
E-Mail: service.tools@inficon.com
www.inficonservicetools.com

074-612-P16B